



Robert Bosch Power Tools GmbH  
70538 Stuttgart  
GERMANY

[www.bosch-pt.com](http://www.bosch-pt.com)

1 609 92A 4H0 (2018.08) AS / 36



1 609 92A 4H0

# GBM Professional

10 | 10 RE



- en Original instructions
- zh 正本使用说明书
- zh 原始使用說明書
- ko 사용 설명서 원본
- th หนังสือนคู่มือการใช้งานฉบับต้นแบบ
- id Petunjuk-Petunjuk untuk Penggunaan Orisinal
- vi Bản gốc hướng dẫn sử dụng

English .....	page	5
中文 .....	页	11
繁體中文 .....	頁	15
한국어 .....	페이지	19
ไทย .....	หน้า	22
Bahasa Indonesia .....	Halaman	27
Tiếng Việt .....	Trang	31

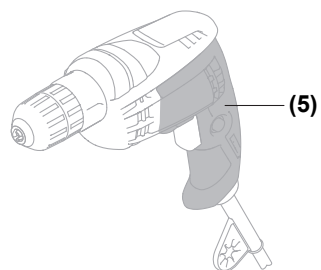
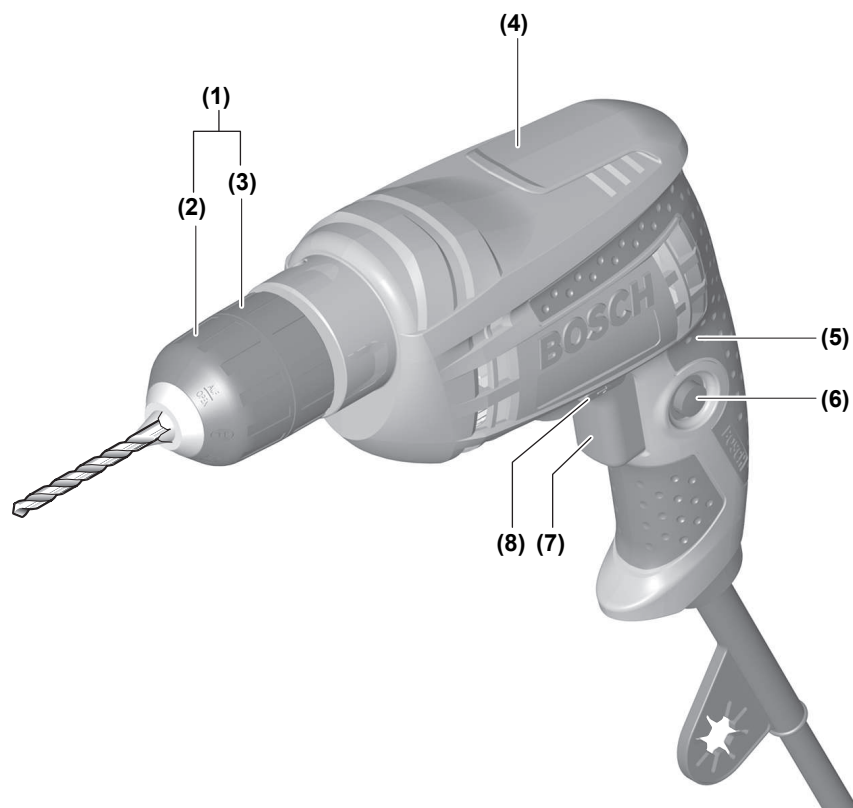

**GBM 10 RE  
Professional**

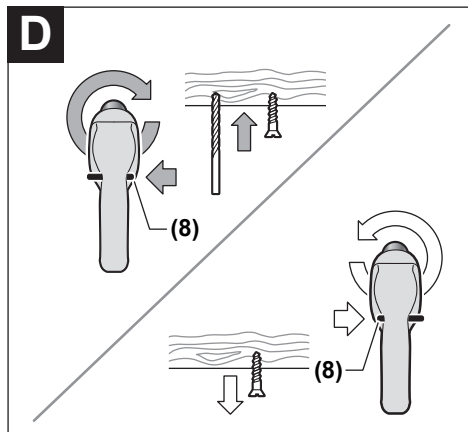
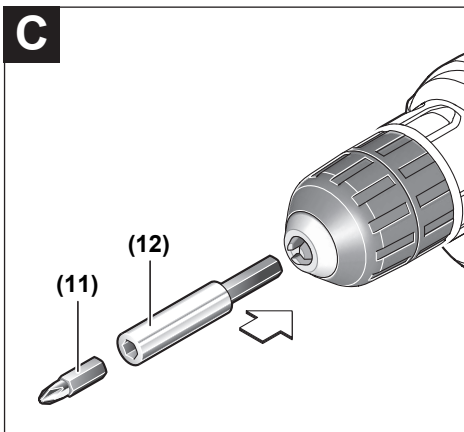
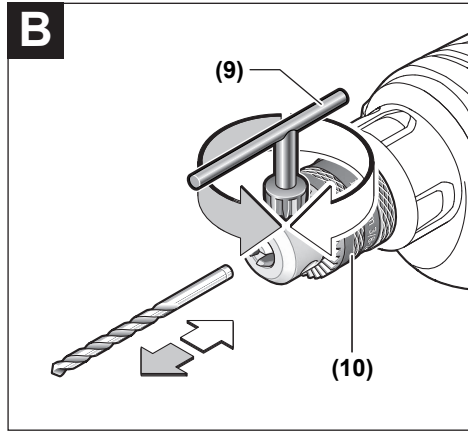
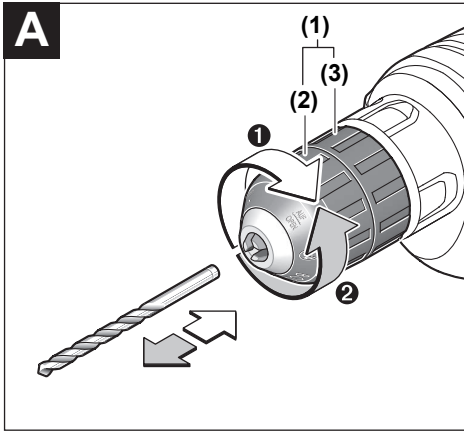

## English

### Safety instructions

#### General Power Tool Safety Warnings

**⚠ WARNING** Read all safety warnings, instructions, illustrations and specifications provided with this power tool. Failure to follow all instructions listed below may result in electric shock, fire and/or serious injury.

**Save all warnings and instructions for future reference.**

The term "power tool" in the warnings refers to your mains-operated (corded) power tool or battery-operated (cordless) power tool.

#### Work area safety

- ▶ **Keep work area clean and well lit.** Cluttered or dark areas invite accidents.
- ▶ **Do not operate power tools in explosive atmospheres, such as in the presence of flammable liquids, gases or dust.** Power tools create sparks which may ignite the dust or fumes.
- ▶ **Keep children and bystanders away while operating a power tool.** Distractions can cause you to lose control.

#### Electrical safety

- ▶ **Power tool plugs must match the outlet. Never modify the plug in any way. Do not use any adapter plugs with earthed (grounded) power tools.** Unmodified plugs and matching outlets will reduce risk of electric shock.
- ▶ **Avoid body contact with earthed or grounded surfaces, such as pipes, radiators, ranges and refrigerators.** There is an increased risk of electric shock if your body is earthed or grounded.
- ▶ **Do not expose power tools to rain or wet conditions.** Water entering a power tool will increase the risk of electric shock.
- ▶ **Do not abuse the cord. Never use the cord for carrying, pulling or unplugging the power tool. Keep cord away from heat, oil, sharp edges or moving parts.** Damaged or entangled cords increase the risk of electric shock.
- ▶ **When operating a power tool outdoors, use an extension cord suitable for outdoor use.** Use of a cord suitable for outdoor use reduces the risk of electric shock.
- ▶ **If operating a power tool in a damp location is unavoidable, use a residual current device (RCD) protected supply.** Use of an RCD reduces the risk of electric shock.

#### Personal safety

- ▶ **Stay alert, watch what you are doing and use common sense when operating a power tool. Do not use a power tool while you are tired or under the influence of drugs, alcohol or medication.** A moment of inatten-

tion while operating power tools may result in serious personal injury.

- ▶ **Use personal protective equipment. Always wear eye protection.** Protective equipment such as a dust mask, non-skid safety shoes, hard hat or hearing protection used for appropriate conditions will reduce personal injuries.
- ▶ **Prevent unintentional starting. Ensure the switch is in the off-position before connecting to power source and/or battery pack, picking up or carrying the tool.** Carrying power tools with your finger on the switch or energising power tools that have the switch on invites accidents.
- ▶ **Remove any adjusting key or wrench before turning the power tool on.** A wrench or a key left attached to a rotating part of the power tool may result in personal injury.
- ▶ **Do not overreach. Keep proper footing and balance at all times.** This enables better control of the power tool in unexpected situations.
- ▶ **Dress properly. Do not wear loose clothing or jewellery. Keep your hair and clothing away from moving parts.** Loose clothes, jewellery or long hair can be caught in moving parts.
- ▶ **If devices are provided for the connection of dust extraction and collection facilities, ensure these are connected and properly used.** Use of dust collection can reduce dust-related hazards.
- ▶ **Do not let familiarity gained from frequent use of tools allow you to become complacent and ignore tool safety principles.** A careless action can cause severe injury within a fraction of a second.

#### Power tool use and care

- ▶ **Do not force the power tool. Use the correct power tool for your application.** The correct power tool will do the job better and safer at the rate for which it was designed.
- ▶ **Do not use the power tool if the switch does not turn it on and off.** Any power tool that cannot be controlled with the switch is dangerous and must be repaired.
- ▶ **Disconnect the plug from the power source and/or remove the battery pack, if detachable, from the power tool before making any adjustments, changing accessories, or storing power tools.** Such preventive safety measures reduce the risk of starting the power tool accidentally.
- ▶ **Store idle power tools out of the reach of children and do not allow persons unfamiliar with the power tool or these instructions to operate the power tool.** Power tools are dangerous in the hands of untrained users.
- ▶ **Maintain power tools and accessories. Check for misalignment or binding of moving parts, breakage of parts and any other condition that may affect the power tool's operation. If damaged, have the power tool repaired before use.** Many accidents are caused by poorly maintained power tools.

- ▶ **Keep cutting tools sharp and clean.** Properly maintained cutting tools with sharp cutting edges are less likely to bind and are easier to control.
- ▶ **Use the power tool, accessories and tool bits etc. in accordance with these instructions, taking into account the working conditions and the work to be performed.** Use of the power tool for operations different from those intended could result in a hazardous situation.
- ▶ **Keep handles and grasping surfaces dry, clean and free from oil and grease.** Slippery handles and grasping surfaces do not allow for safe handling and control of the tool in unexpected situations.

#### Service

- ▶ **Have your power tool serviced by a qualified repair person using only identical replacement parts.** This will ensure that the safety of the power tool is maintained.

### Safety Warnings for Drills

#### Safety instructions for all operations

- ▶ **Hold the power tool by insulated gripping surfaces, when performing an operation where the cutting accessory may contact hidden wiring or its own cord.** Cutting accessory contacting a "live" wire may make exposed metal parts of the power tool "live" and could give the operator an electric shock.

#### Safety instructions when using long drill bits

- ▶ **Never operate at higher speed than the maximum speed rating of the drill bit.** At higher speeds, the bit is likely to bend if allowed to rotate freely without contacting the workpiece, resulting in personal injury.
- ▶ **Always start drilling at low speed and with the bit tip in contact with the workpiece.** At higher speeds, the bit is likely to bend if allowed to rotate freely without contacting the workpiece, resulting in personal injury.
- ▶ **Apply pressure only in direct line with the bit and do not apply excessive pressure.** Bits can bend causing breakage or loss of control, resulting in personal injury.

#### Additional safety warnings

- ▶ **Secure the workpiece.** A workpiece clamped with clamping devices or in a vice is held more secure than by hand.
- ▶ **Switch the power tool off immediately if the application tool becomes blocked. Be prepared for high torque reactions which cause kickback.** The application tool becomes blocked when it becomes jammed in the workpiece or when the power tool becomes overloaded.
- ▶ **Use suitable detectors to determine if utility lines are hidden in the work area or call the local utility company for assistance.** Contact with electric lines can lead to fire and electric shock. Damaging a gas line can lead to

explosion. Penetrating a water line causes property damage or may cause an electric shock.

- ▶ **Always wait until the power tool has come to a complete stop before placing it down.** The application tool can jam and cause you to lose control of the power tool.

#### Products sold in GB only:

Your product is fitted with an BS 1363/A approved electric plug with internal fuse (ASTA approved to BS 1362).

If the plug is not suitable for your socket outlets, it should be cut off and an appropriate plug fitted in its place by an authorised customer service agent. The replacement plug should have the same fuse rating as the original plug.

The severed plug must be disposed of to avoid a possible shock hazard and should never be inserted into a mains socket elsewhere.

## Product Description and Specifications



#### Read all the safety and general instructions.

Failure to observe the safety and general instructions may result in electric shock, fire and/or serious injury.

Please observe the illustrations at the beginning of this operating manual.

#### Intended Use

The power tool is suitable for drilling in wood, metal, ceramic and plastic. Power tools with electronic control and right/left rotation are also suitable for screwdriving and thread cutting.

#### Product Features

The numbering of the product features refers to the diagram of the power tool on the graphics page.

- (1) Keyless chuck <sup>A)</sup>
- (2) Front sleeve
- (3) Rear sleeve
- (4) Belt clip
- (5) Handle (insulated gripping surface)
- (6) Lock-on button for on/off switch
- (7) On/off switch
- (8) Rotational direction switch (GBM 10 RE)
- (9) Chuck key <sup>A)</sup>
- (10) Keyed chuck <sup>A)</sup>
- (11) Screwdriver bit <sup>A)</sup>
- (12) Universal bit holder <sup>A)</sup>

A) **Accessories shown or described are not included with the product as standard. You can find the complete selection of accessories in our accessories range.**

## Technical Data

Drill		GBM 10	GBM 10 RE	GBM 10 RE
Article number		<b>3 601 D73 0..</b>	<b>3 601 D73 5..</b>	<b>3 601 D73 6..</b>
Rated power input	W	450	450	450
Power output	W	236	236	236
No-load speed	rpm	2 600	0–2 600	0–2 600
Rated speed	rpm	1 760	0–1 760	0–1 760
Rated torque	Nm	14	14	14
Spindle collar diameter	mm	43	43	43
Speed control		–	●	●
Right/left rotation		–	●	●
Keyed chuck		●	●	–
Keyless chuck		–	–	●
Max. drilling diameter				
– Steel	mm	10	10	10
– Wood	mm	25	25	25
– Aluminium	mm	10	10	10
Chucking capacity	mm	1–10	1–10	1–10
Weight according to EPTA-Procedure 01:2014	kg	1.3	1.3	1.3
Protection class		□/II	□/II	□/II

The specifications apply to a rated voltage [U] of 230 V. These specifications may vary at different voltages and in country-specific models.

## Assembly

- ▶ **Pull the plug out of the socket before carrying out any work on the power tool.**

### Changing the Tool

- ▶ **Wear protective gloves when changing tools.** The drill chuck may heat up significantly when it is used for long periods.

#### Keyless Chuck (see figure A)

Hold the rear sleeve **(3)** of the keyless chuck **(1)** firmly and turn the front sleeve **(2)** in the rotational direction **⚙** until the tool can be inserted. Insert the tool.

Hold the rear sleeve **(3)** of the keyless chuck **(1)** and firmly tighten the front sleeve **(2)** by hand in the rotational direction **⚙** until it stops clicking. This will automatically lock the drill chuck.

The lock will disengage again if you turn the front sleeve **(2)** in the opposite direction to remove the tool.

#### Keyed chuck with automatic lock (see figure B)

Open the keyed chuck **(10)** by turning it until the tool can be inserted.

Insert the tool. Insert the drill chuck key **(9)** into the corresponding holes of the keyed chuck **(10)** and clamp the tool evenly.

### Screwdriving Tools (see figure C)

You should always use a universal bit holder **(12)** when using screwdriver bits **(11)**. Only use screwdriver bits that fit the screw head.

### Changing the drill chuck

If your power tool does not have a drill spindle locking mechanism, you must have the drill chuck changed by an authorised after-sales service centre for Bosch power tools.



**The drill chuck must be tightened using a tightening torque of approx. 31–35 Nm.**

### Dust/Chip Extraction

Dust from materials such as lead-containing coatings, some wood types, minerals and metal can be harmful to one's health. Touching or breathing-in the dust can cause allergic reactions and/or lead to respiratory infections of the user or bystanders.

Certain dust, such as oak or beech dust, is considered carcinogenic, especially in connection with wood-treatment additives (chromate, wood preservative). Materials containing asbestos may only be worked by specialists.

- Provide for good ventilation of the working place.
- It is recommended to wear a P2 filter-class respirator.

Observe the relevant regulations in your country for the materials to be worked.

- ▶ **Avoid dust accumulation at the workplace.** Dust can easily ignite.

## Operation

### Starting Operation

- ▶ **Pay attention to the mains voltage. The voltage of the power source must match the voltage specified on the rating plate of the power tool. Power tools marked with 230 V can also be operated with 220 V.**
- ▶ **Products that are only sold in AUS and NZ:** Use a residual current device (RCD) with a nominal residual current of 30 mA or less.

### Setting the Rotational Direction (GBM 10 RE) (see figure D)

The rotational direction switch (8) is used to change the rotational direction of the power tool. However, this is not possible while the on/off switch (7) is being pressed.

**Right rotation:** To drill and to drive in screws, press the rotational direction switch (8) through to the left stop.

**Left Rotation:** To loosen and unscrew screws and nuts, press the rotational direction switch (8) through to the right stop.

### Switching on/off

To **start** the power tool, press and hold the on/off switch (7).

Press the lock-on button (6) to **lock** the on/off switch (7) in this position.

To **switch off** the power tool, release the on/off switch (7); or, if the switch is locked with the lock-on button (6), briefly press the on/off switch (7) and then release it.

### Adjusting the Speed (GBM 10 RE)

You can adjust the speed of the power tool when it is on by pressing in the on/off switch (7) to varying extents.

Applying light pressure to the on/off switch (7) results in a low rotational speed. Increased pressure on the switch causes an increase in speed.

### Practical advice

- ▶ **Pull the plug out of the socket before carrying out any work on the power tool.**
- ▶ **Only apply the power tool to the screw/nut when the tool is switched off.** Rotating tool inserts can slip off.

When drilling into metal, only use sharpened HSS drills (HSS = high-speed steel) which are in perfect condition. The Bosch accessory range guarantees appropriate quality.

Using the drill bit sharpener (accessory), you can effortlessly sharpen twist drill bits with a diameter of 2.5–10 mm.

Use a drill stand (accessory) for jobs that require particular precision.

The machine vice, which is available as an accessory, enables the workpiece to be securely clamped. This prevents the workpiece from turning and any accidents this could cause.

After working at a low speed for an extended period, you should operate the power tool at the maximum speed for approximately three minutes without load to cool it down.

Before screwing larger, longer screws into hard materials, it is advisable to pre-drill a pilot hole with the core diameter of the thread to approx. 2/3 of the screw length.

### Belt clip

You can use the belt clip (4) to hang the power tool on a belt, for example. You then have both hands free and the power tool is always at hand.

## Maintenance and Servicing

### Maintenance and Cleaning

- ▶ **Pull the plug out of the socket before carrying out any work on the power tool.**
- ▶ **To ensure safe and efficient operation, always keep the power tool and the ventilation slots clean.**

In order to avoid safety hazards, if the power supply cord needs to be replaced, this must be done by Bosch or by a customer service centre that is authorised to repair Bosch power tools.

### After-sales Service and Advice on Using Products

Our after-sales service can answer questions concerning product maintenance and repair, as well as spare parts. You can find exploded drawings and information on spare parts at: [www.bosch-pt.com](http://www.bosch-pt.com)

The Bosch product use advice team will be happy to help you with any questions about our products and their accessories.

[www.powertool-portal.de](http://www.powertool-portal.de), the internet portal for tradespeople and DIY enthusiasts.

In all correspondence and spare parts orders, please always include the 10-digit article number given on the type plate of the product.

### Cambodia

Robert Bosch (Cambodia) Co., Ltd  
Unit 8BC, GT Tower, 08th Floor, Street 169,  
Czechoslovakia Blvd, Sangkat Veal Vong  
Khan 7 Makara, Phnom Penh  
VAT TIN: 100 169 511  
Tel.: +855 23 900 685  
Tel.: +855 23 900 660  
[www.bosch.com.kh](http://www.bosch.com.kh)

### People's Republic of China

#### China Mainland

Bosch Power Tool (China) Co. Ltd.  
Bosch Service Center  
567, Bin Kang Road  
Bin Kang District  
Hangzhou, Zhejiang Province  
China 310052  
Tel.: (0571) 8887 5566 / 5588  
Fax: (0571) 8887 6688 x 5566# / 5588#



E-mail: [bsc.hz@cn.bosch.com](mailto:bsc.hz@cn.bosch.com)  
[www.bosch-pt.com.cn](http://www.bosch-pt.com.cn)

#### **HK and Macau Special Administrative Regions**

Robert Bosch Co. Ltd.  
 21st Floor, 625 King's Road  
 North Point, Hong Kong  
 Customer Service Hotline: +852 2101 0235  
 Fax: +852 2590 9762  
 E-mail: [info@hk.bosch.com](mailto:info@hk.bosch.com)  
[www.bosch-pt.com.hk](http://www.bosch-pt.com.hk)

#### **India**

Bosch Service Center  
 69, Habibullah Road, (next to PSBB School), T. Nagar  
 Chennai-600077  
 Phone: (044) 64561816  
 Bosch Service Center Rishyamook  
 85A, Panchkuin Road  
 New Delhi-110001  
 Phone: (011) 43166190  
 Bosch Service Center 79,  
 Crystal Bldg., Dr. Annie Besant Road, Worli  
 Mumbai-400018  
 Phone: (022) 39569936 / (022) 39569959 /  
 (022) 39569967 / (022) 24952071

#### **Indonesia**

PT Robert Bosch  
 Palma Tower 10th Floor  
 Jalan RA Kartini II-S Kaveling 6  
 Pondok Pinang, Kebayoran Lama  
 Jakarta Selatan 12310  
 Tel.: (21) 3005-5800  
[www.bosch-pt.co.id](http://www.bosch-pt.co.id)

#### **Malaysia**

Robert Bosch Sdn. Bhd. (220975-V) PT/SMY  
 No. 8A, Jalan 13/6  
 46200 Petaling Jaya  
 Selangor  
 Tel.: (03) 79663194  
 Toll-Free: 1800 880188  
 Fax: (03) 79583838  
 E-mail: [kiathoe.chong@my.bosch.com](mailto:kiathoe.chong@my.bosch.com)  
[www.bosch-pt.com.my](http://www.bosch-pt.com.my)

#### **Pakistan**

Robert Bosch Middle East FZE – Pakistan Liaison Office  
 2nd Floor Plaza # 10, CCA Block, DHA Phase 5  
 Lahore, 54810  
 Phone: +92(303)4444311  
 E-mail: [Faisal.Khan@bosch.com](mailto:Faisal.Khan@bosch.com)

#### **Philippines**

Robert Bosch, Inc.  
 28th Floor Fort Legend Towers,  
 3rd Avenue corner 31st Street,  
 Fort Bonifacio, Global City,  
 1634 Taguig City  
 Tel.: (632) 8703871  
 Fax: (632) 8703870  
[www.bosch-pt.com.ph](http://www.bosch-pt.com.ph)

#### **Singapore**

Powerwell Service Centre Ptd Ltd  
 Bosch Authorised Service Centre (Power Tools)  
 4012 Ang Mo Kio Ave 10, #01-02 TECHplace  
 Singapore 569628  
 Tel.: 6452 1770  
 Fax: 6452 1760  
 E-mail: [ask@powerwellsc.com](mailto:ask@powerwellsc.com)  
[www.powerwellsc.com](http://www.powerwellsc.com)  
[www.bosch-pt.com.sg](http://www.bosch-pt.com.sg)

#### **Thailand**

Robert Bosch Ltd.  
 Liberty Square Building  
 No. 287, 11 Floor  
 Silom Road, Bangrak  
 Bangkok 10500  
 Tel.: 02 6393111  
 Fax: 02 2384783  
 Robert Bosch Ltd., P. O. Box 2054  
 Bangkok 10501  
[www.bosch.co.th](http://www.bosch.co.th)  
 Bosch Service – Training Centre  
 La Salle Tower Ground Floor Unit No.2  
 10/11 La Salle Moo 16  
 Srinakharin Road  
 Bangkaew, Bang Plee  
 Samutprakarn 10540  
 Tel.: 02 7587555  
 Fax: 02 7587525

#### **Vietnam**

Branch of Bosch Vietnam Co., Ltd in HCMC  
 14th floor, Deutsches Haus, 33 Le Duan  
 Ben Nghe Ward, District 1, Ho Chi Minh City  
 Tel.: (028) 6258 3690  
 Fax: (028) 6258 3692 - 6258 3694  
 Hotline: (028) 6250 8555  
 E-mail: [tuvankhachhang-pt@vn.bosch.com](mailto:tuvankhachhang-pt@vn.bosch.com)  
[www.bosch-pt.com.vn](http://www.bosch-pt.com.vn)

#### **Armenia, Azerbaijan, Georgia, Kyrgyzstan, Mongolia, Tajikistan, Turkmenistan, Uzbekistan**

TOO "Robert Bosch" Power Tools, After Sales Service  
 Rayimbek Ave., 169/1  
 050050, Almaty, Kazakhstan  
 Service e-mail: [service.pt.ka@bosch.com](mailto:service.pt.ka@bosch.com)  
 Official website: [www.bosch.com](http://www.bosch.com), [www.bosch-pt.com](http://www.bosch-pt.com)

#### **Bahrain**

Hatem Al Juffali Technical Equipment Establishment.  
 Kingdom of Bahrain, Setra Highway, Al Aker Area  
 Phone: +966126971777-311  
 Fax: +97317704257  
 E-mail: [h.berjas@ejb.com.sa](mailto:h.berjas@ejb.com.sa)  
 Egypt  
 Unimar  
 20 Markaz kadmat  
 El tagmoa EL Aoul – New Cairo  
 Phone: +20 2224 76091-95  
 Phone: +20 2224 78072-73

Fax: +20222478075  
E-mail: adelzaki@unimaregypt.com

**Iran**

Robert Bosch Iran  
3rd Floor, No 3, Maadiran Building  
Aftab St., Khodami St., Vanak Sq.  
Tehran 1994834571  
Phone: +9821 86092057

**Iraq**

Sahba Technology Group  
Al Muthana airport road  
Baghdad  
Phone: +9647901906953  
Phone Dubai: +97143973851  
E-mail: bosch@sahbatechnology.com

**Jordan**

Roots Arabia – Jordan  
Nasser Bin Jameel street, Building 37 Al Rabiah  
11194 Amman  
Phone: +962 6 5545778  
E-mail: bosch@rootsjordan.com

**Kuwait**

Al Qurain Automotive Trading Company  
Shuwaikh Industrial Area, Block 1, Plot 16, Street 3rd  
P.O. Box 164 – Safat 13002  
Phone: 24810844  
Fax: 24810879  
E-mail: josephkr@aaalmutawa.com

**Lebanon**

Tehini Hana & Co. S.A.R.L.  
P.O. Box 90-449  
Jdeideh  
Dora-Beirut  
Phone: +9611255211  
E-mail: service-pt@tehini-hana.com

**Libya**

El Naser for Workshop Tools  
Swanee Road, Alfalah Area  
Tripoli  
Phone: +218 21 4811184

**Oman**

Malatan Trading & Contracting LLC  
P.O. Box 131  
Ruwi, 112 Sultanate of Oman  
Phone: +968 99886794  
E-mail: malatanpowertools@malatan.net

**Qatar**

International Construction Solutions W L L  
P. O. Box 51,  
Doha Phone: +974 40065458  
Fax: +974 4453 8585  
E-mail: csd@icsdoha.com

**Saudi Arabia**

Juffali Technical Equipment Co. (JTECO)  
Kilo 14, Madinah Road, Al Bawadi District  
Jeddah 21431

Phone: +966 2 6672222 Ext. 1528  
Fax: +966 2 6676308  
E-mail: roland@ejb.com.sa

**Syria**

Dallal Establishment for Power Tools  
P.O. Box 1030  
Aleppo  
Phone: +963212116083  
E-mail: rita.dallal@hotmail.com

**United Arab Emirates**

Central Motors & Equipment LLC, P.O. Box 1984  
Al-Wahda Street – Old Sana Building  
Sharjah  
Phone: +971 6 593 2777  
Fax: +971 6 533 2269  
E-mail: powertools@centralsmotors.ae

**Yemen**

Abualrejal Trading Corporation  
Sana'a Zubairy St. Front to new Parliament Building  
Phone: +967-1-202010  
Fax: +967-1-279029  
E-mail: tech-tools@abualrejal.com

**Ethiopia**

Forever plc  
Kebele 2,754, BP 4806,  
Addis Ababa  
Phone: +251 111 560 600  
E-mail: foreverplc@ethionet.et

**Ghana**

C.WOERMANN LTD.  
Nsawam Road/Avenor Junction, P.O. Box 1779  
Accra Phone: +233 302 225 141

**Kenya**

Robert Bosch East Africa Ltd  
Mpaka Road P.O. Box 856  
00606 Nairobi

**Nigeria**

Robert Bosch Nigeria Ltd.  
52–54 Isaac John Street P.O. Box  
GRA Ikeja – Lagos

**Republic of South Africa****Customer service**

Hotline: (011) 6519600

**Gauteng – BSC Service Centre**

35 Roper Street, New Centre  
Johannesburg  
Tel.: (011) 4939375  
Fax: (011) 4930126  
E-mail: bsctools@icon.co.za

**KZN – BSC Service Centre**

Unit E, Almar Centre  
143 Crompton Street  
Pinetown  
Tel.: (031) 7012120  
Fax: (031) 7012446  
E-mail: bsc.dur@za.bosch.com

**Western Cape – BSC Service Centre**

Democracy Way, Prosperity Park  
Milnerton

Tel.: (021) 5512577

Fax: (021) 5513223

E-mail: bsc@zsd.co.za

**Bosch Headquarters**

Midrand, Gauteng

Tel.: (011) 6519600

Fax: (011) 6519880

E-mail: rbsa-hq.pts@za.bosch.com

**Tanzania**

Diesel & Autoelectric Service Ltd.  
117 Nyerere Rd., P.O. Box 70839  
Vingunguti 12109, Dar Es Salaam  
Phone: +255 222 861 793/794

**Australia, New Zealand and Pacific Islands**

Robert Bosch Australia Pty. Ltd.  
Power Tools

Locked Bag 66  
Clayton South VIC 3169  
Customer Contact Center

Inside Australia:

Phone: (01300) 307044

Fax: (01300) 307045

Inside New Zealand:

Phone: (0800) 543353

Fax: (0800) 428570

Outside AU and NZ:

Phone: +61 3 95415555

www.bosch-pt.com.au

www.bosch-pt.co.nz

**Disposal**

The power tool, accessories and packaging should be recycled in an environmentally friendly manner.



Do not dispose of power tools along with household waste.

## 中文

### 安全规章

#### 电动工具通用安全警告

**⚠警告！** 阅读随电动工具提供的所有安全警告、说明、图示和规定。不遵照以下所列说明会导致电击、着火和/或严重伤害。

保存所有警告和说明书以备查阅。

警告中的术语“电动工具”是指市电驱动（有线）电动工具或电池驱动（无线）电动工具。

#### 工作场地的安全

- ▶ **保持工作场地清洁和明亮。** 杂乱和黑暗的场地会引发事故。
- ▶ **不要在易爆环境，如有易燃液体、气体或粉尘的环境下操作电动工具。** 电动工具产生的火花会点燃粉尘或气体。
- ▶ **操作电动工具时，远离儿童和旁观者。** 注意力不集中会使你失去对工具的控制。

#### 电气安全

- ▶ **电动工具插头必须与插座相配。绝不能以任何方式改装插头。** 需接地的电动工具不能使用任何转换插头。未经改装的插头和相配的插座将降低电击风险。
- ▶ **避免人体接触接地表面，如管道、散热片和冰箱。** 如果你身体接触接地表面会增加电击风险。
- ▶ **不得将电动工具暴露在雨中或潮湿环境中。** 水进入电动工具将增加电击风险。
- ▶ **不得滥用软线。** 绝不能用软线搬运、拉动电动工具或拔出其插头。使软线远离热源、油、锐边或运动部件。受损或缠绕的软线会增加电击风险。
- ▶ **当在户外使用电动工具时，使用适合户外使用的延长线。** 适合户外使用的电线将降低电击风险。
- ▶ **如果无法避免在潮湿的环境中操作电动工具，应使用带有剩余电流装置（RCD）保护的电源。** RCD的使用可降低电击风险。

#### 人身安全

- ▶ **保持警觉，当操作电动工具时关注所从事的操作并保持清醒。** 当你感到疲倦，或在有药物、酒精或治疗反应时，不要操作电动工具。在操作电动工具时瞬间的疏忽会导致严重人身伤害。
- ▶ **使用个人防护装置。始终佩戴护目镜。** 防护装置，诸如适当条件下使用防尘面具、防滑安全鞋、安全帽、听力防护等装置能减少人身伤害。
- ▶ **防止意外起动。在连接电源和/或电池包、拿起或搬运工具前确保开关处于关断位置。** 手指放在开关上搬运工具或开关处于接通时通电会导致危险。
- ▶ **在电动工具接通之前，拿掉所有调节钥匙或扳手。** 遗留在电动工具旋转零件上的扳手或钥匙会导致人身伤害。
- ▶ **手不要过分伸展。时刻注意立足点和身体平衡。** 这样能在意外情况下能更好地控制住电动工具。
- ▶ **着装适当。不要穿宽松衣服或佩戴饰品。** 让你的头发和衣服远离运动部件。宽松衣服、佩戴或长发可能会卷入运动部件。
- ▶ **如果提供了与排屑、集尘设备连接用的装置，要确保其连接完好且使用得当。** 使用集尘装置可降低尘屑引起的危险。
- ▶ **不要因为频繁使用工具而产生的熟悉感而掉以轻心，忽视工具的安全准则。** 某个粗心的动作可能在瞬间导致严重的伤害。

### 电动工具使用和注意事项

- ▶ **不要勉强使用电动工具，根据用途使用合适的电动工具。** 选用合适的按照额定值设计的电动工具会使你工作更有效、更安全。
- ▶ **如果开关不能接通或断开电源，则不能使用该电动工具。** 不能通过开关来控制的电动工具是危险的且必须进行修理。
- ▶ **在进行任何调节、更换附件或贮存电动工具之前，必须从电源上拔掉插头和/或卸下电池包（如可拆卸）。** 这种防护性的安全措施降低了电动工具意外起动的风险。
- ▶ **将闲置不用的电动工具存放在儿童所及范围之外，并且不允许不熟悉电动工具和不了解这些说明的人操作电动工具。** 电动工具在未经培训的使用者手中是危险的。
- ▶ **维护电动工具及其附件。检查运动部件是否调整到位或卡住，检查零件破损情况和影响电动工具运行的其他状况。** 如有损坏，应在使用前修理好电动工具。许多事故是由维护不良的电动工具引发的。
- ▶ **保持切削刀具锋利和清洁。** 维护良好地有锋利切削刃的刀具不易卡住而且容易控制。
- ▶ **按照使用说明书，并考虑作业条件和要进行的作业来选择电动工具、附件和工具的刀头等。** 将电动工具用于那些与其用途不符的操作可能会导致危险情况。
- ▶ **保持手柄和握持表面干燥、清洁，不得沾有油脂。** 在意外的情况下，湿滑的手柄不能保证握持的安全和对工具的控制。

### 维修

- ▶ **由专业维修人员使用相同的备件维修电动工具。** 这将保证所维修的电动工具的安全。

### 电钻安全警告

#### 适用于全部操作的安全说明

- ▶ **当在钻削附件可能触及暗线或其自身导线的场合进行操作时，要通过绝缘握持面握持工具。** 钻削附件碰到带电导线会使工具外露的金属零件带电而使操作者受到电击。

#### 当使用长钻头时的安全说明

- ▶ **操作时切勿超出钻头的最大额定转速。** 在较高转速下，如果让钻头在不接触工件的情况下随意旋转，很可能导致其弯折，从而引发人身伤害。
- ▶ **务必以低转速开始钻孔，并让钻头尖端与工件接触。** 在较高转速下，如果让钻头在不接触工件的情况下随意旋转，很可能导致其弯折，从而引发人身伤害。

### 技术数据

电钻	GBM 10	GBM 10 RE	GBM 10 RE
物品代码	3 601 D730..	3 601 D735..	3 601 D736..
额定输入功率	瓦	450	450

- ▶ **施压时务必与钻头成一直线，且不得施加过大压力。** 若钻头弯折会导致其损坏或失控，从而引发人身伤害。

### 其它安全规章

- ▶ **固定好工件。** 使用固定装置或老虎钳固定工件，会比用手握工件更牢固。
- ▶ **当工具刀头被夹住时，请立即关闭电动工具。** 以防反作用力矩导致反弹。当电动工具过载或向待加工工件倾斜时，工具刀头就会卡住。
- ▶ **使用合适的侦测装置侦察隐藏的电线，或者向当地的相关单位寻求支援。** 接触电线可能引起火灾并让操作者触电。损坏了瓦斯管会引起爆炸。凿穿水管不仅会造成严重的财物损失，也可能导致触电。
- ▶ **等待电动工具完全静止后才能够放下机器。** 机器上的工具可能在工作中被夹住，而令您无法控制电动工具。

### 产品和性能说明



请阅读所有安全规章和指示。不遵照以下警告和说明可能导致电击、着火和/或严重伤害。

请注意本使用说明书开头部分的图示。

### 按照规定使用

GBM、TBM代表电钻，GSB、TSB代表冲击电钻。本电动工具适合在木材、金属、陶瓷和塑料上钻孔。配备电子调节装置和正/逆转开关的机器也可以拧入/拧出螺丝或攻丝。

### 插图上的机件

机件的编号和电动工具详解图上的编号一致。

- (1) 快速夹头<sup>A)</sup>
- (2) 前套筒
- (3) 后套筒
- (4) 腰带夹
- (5) 手柄（绝缘握柄）
- (6) 起停开关的锁紧键
- (7) 起停开关
- (8) 正逆转开关（GBM 10 RE）
- (9) 夹头扳手<sup>A)</sup>
- (10) 齿环夹头<sup>A)</sup>
- (11) 螺丝批嘴<sup>A)</sup>
- (12) 通用批嘴架<sup>A)</sup>

A) 图表或说明上提到的附件，并不包含在基本的供货范围中。本公司的附件清单中有完整的附件供应项目。

电钻		GBM 10	GBM 10 RE	GBM 10 RE
输出功率	瓦	236	236	236
无负载转速	转/分钟	2 600	0-2 600	0-2 600
额定转速	转/分钟	1 760	0-1 760	0-1 760
额定扭力	牛米	14	14	14
主轴颈直径	毫米	43	43	43
转速控制装置		-	●	●
正/逆转功能		-	●	●
齿环夹头		●	●	-
快速夹头		-	-	●
最大钻孔直径				
- 钢	毫米	10	10	10
- 木材	毫米	25	25	25
- 铝	毫米	10	10	10
夹头的夹紧范围	毫米	1-10	1-10	1-10
重量符合EPTA-Procedure 01:2014	千克	1.3	1.3	1.3
保护等级		□/II	□/II	□/II

所有参数适用于230伏的额定电压[U]，对于其他不同的电压和国际规格，数据有可能不同。

## 安装

- ▶ **在电动工具上进行所有操作之前都必须从插座上拔出电源插头。**

### 更换工具

- ▶ **更换刀具时，请佩戴保护手套。**长时间工作之后夹头会变得十分炽热。

#### 快速夹头（见图片A）

握住快速夹头(1)的后套筒(3)，沿⊙方向旋转前套筒(2)，直至可以安装工具为止。安装好工具。

握住快速夹头(1)的后套筒(3)，用手朝着⊙方向用力旋转前套筒(2)，直至不再听到过于卡紧的声音为止。由此钳夹头会被自动锁止。

反向转动前套筒(2)来移除工具时，锁止件再次自动松开。

#### 带自动锁定功能的齿环夹头（见图片B）

旋转打开齿环夹头(10)，直至可以装入工具。

安装好工具。将夹头扳手(9)插入齿环夹头(10)相应的孔中，然后均匀拧紧工具。

#### 起子机的工具（见图片C）

使用螺丝批嘴(11)时，应当使用通用批嘴架(12)。必须使用与螺丝头大小相符的螺丝批嘴。

### 更换夹头

如果电动工具本身没有主轴锁定功能，更换夹头的工作必须交给经过授权的博世电动工具客户服务处执行。



**必须以31 - 35牛米的拧紧力矩拧紧钻夹头。**

## 抽吸粉尘/切屑

含铅的颜料以及某些木材、矿物和金属的加工废尘有害健康。机器操作者或者工地附近的人如果接触、吸入这些废尘，可能会有过敏反应或者感染呼吸道疾病。

某些尘埃（例如加工橡木或山毛榉的废尘）可能致癌，特别是和处理木材的添加剂（例如木材的防腐剂等）结合之后。只有经过专业训练的人才能够加工含石棉的物料。

- 工作场所要保持空气流通。
- 最好佩戴P2滤网等级的口罩。

请留心并遵守贵国和加工物料有关的法规。

- ▶ **避免让工作场所堆积过多的尘垢。**尘埃容易被点燃。

## 运行

### 投入使用

- ▶ **注意电源电压！**电源的电压必须和电动工具铭牌上标示的电压一致。标记为230伏电动工具用220伏的电压可以驱动。

#### 调整旋转方向（GBM 10 RE）（见图片D）

通过正逆转开关(8)可以更改电动工具的旋转方向。按下起停开关(7)后无法更改。

**正转：**钻孔和旋入螺栓时，向左按压正逆转开关(8)直至极限位置。

**逆转：**松开或拧出螺丝和螺母时，向右按压正逆转开关(8)直至极限位置。

#### 接通/关闭

将电动工具**投入使用**时按压起停开关(7)并按住。

如需**锁定**被按住的起停开关(7)，请按压锁定键(6)。

如需关闭电动工具，请松开起停开关(7)，如果其已被锁定键(6)锁住，请短促按压起停开关(7)，然后再松开。

#### 调整转速 (GBM 10 RE)

可以无级调节已接通电动工具的转速，视按压起停开关(7)的力道程度决定。

以较小的力按压起停开关(7)时，转速较低。逐渐在开关上加压，转速也会跟着提高。

#### 工作提示

- ▶ 在电动工具上进行所有操作之前都必须从插座上拔出电源插头。
- ▶ 先关闭电动工具，然后再放置在螺母/螺栓上。旋转的工具刀头可能会滑开。

在金属上钻孔时，仅可使用锋利的HSS钻头（HSS=高速钢）。在博世的附件产品系列中，有符合这个品质等级的产品。

可通过钻头刃磨机（附件）毫不费力地磨利直径在2.5 - 10毫米的麻花钻。

进行精密的钻孔工作时，最好使用钻台（附件）。机器台钳作为附件购买，能够牢牢地夹住工件。它可以避免工件扭转，从而防止事故发生。

使用低转速长时间操作之后，应该让电动工具以最大转速空转约3分钟来帮助机器冷却。

把大的、长的螺丝拧入坚硬的物料中之前，必须根据螺纹的中心直径预钻孔，预钻孔的深度大概为螺丝长度的2/3。

#### 腰带夹

使用腰带夹(4)可以把电动工具挂在例如腰带上。不但能够空出双手，而且可随时够到电动工具。

## 维修和服务

#### 维护和清洁

- ▶ 在电动工具上进行所有操作之前都必须从插座上拔出电源插头。
- ▶ 电动工具和通气孔必须随时保持清洁，以确保工作效率和工作安全。

如果必须更换连接线，务必把这项工作交给博世或者经授权的博世电动工具客户服务执行，以避免危害机器的安全性能。

## 客户服务和应用咨询

本公司顾客服务处负责回答有关本公司产品的修理、维护和备件的问题。备件的分解图和信息也可查看：[www.bosch-pt.com](http://www.bosch-pt.com)

博世应用咨询团队乐于就我们的产品及其附件问题提供帮助。

[www.powertool-portal.de](http://www.powertool-portal.de)，适合工匠和DIY者的互联网门户网站。

如需查询和订购备件，请务必提供产品型号铭牌上的10位数货号。

#### 香港和澳门特别行政区

罗伯特博世有限公司  
香港北角英皇道625号，  
21楼  
客户服务热线：+852 2101 0235  
传真：+852 2590 9762  
电子邮件：[info@hk.bosch.com](mailto:info@hk.bosch.com)  
[www.bosch-pt.com.hk](http://www.bosch-pt.com.hk)

#### 中国大陆

博世电动工具（中国）有限公司，中国浙江省杭州市滨江区滨康路567号  
102/1F服务中心  
邮政编码：310052  
电话：(0571) 8887 5566 / 5588  
传真：(0571) 8887 6688 x 5566# / 5588#  
电邮：[bsc.hz@cn.bosch.com](mailto:bsc.hz@cn.bosch.com)

#### 中华人民共和国

#### 中国大陆

博世电动工具（中国）有限公司  
博世服务中心  
中国浙江省杭州市滨江区滨康路567号，  
310052  
电话：(0571) 8887 5566 / 5588  
传真：(0571) 8887 6688 x 5566# / 5588#  
电子邮件：[bsc.hz@cn.bosch.com](mailto:bsc.hz@cn.bosch.com)  
[www.bosch-pt.com.cn](http://www.bosch-pt.com.cn)

#### 处理废弃物

必须以符合环保要求的方式回收再利用电动工具、附件和包装材料。



请勿将电动工具扔到生活垃圾中！

产品中有害物质的名称及含量

部件名称	有害物质					
	铅 (Pb)	汞 (Hg)	镉 (Cd)	六价铬 (Cr <sup>+6</sup> )	多溴联苯 (PBB)	多溴二苯醚 (PBDE)
外壳的金属部分	0	0	0	0	0	0
外壳的非金属部分	0	0	0	0	0	0

部件名稱	有害物質					
	鉛 (Pb)	汞 (Hg)	鎘 (Cd)	六價鉻 (Cr <sup>+6</sup> )	多溴聯苯 (PBB)	多溴二苯醚 (PBDE)
機械傳動機構	X	0	0	0	0	0
電機組件	X	0	0	0	0	0
控制組件	X	0	0	0	0	0
附件	0	0	0	0	0	0
配件	0	0	0	0	0	0
連接件	X	0	0	0	0	0
電源線* ①	0	0	0	0	0	0
電池系統* ②	X	0	0	0	0	0

本表格依據SJ/T11364 的規定編制。

0：表示該有害物質在該部件所有均質材料中的含量均在GB/T 26572 規定的限量要求以下。

X：表示該有害物質至少在該部件的某一均質材料中的含量超出GB/T 26572 規定的限量要求。

且目前業界沒有成熟的替代方案，符合歐盟RoHS 指令環保要求。

① 適用於採用電源線連接供電的產品。

② 適用於採用充電電池供電的產品。

產品環保使用期限內的使用條件參見產品說明書。

## 繁體中文

### 安全注意事項

#### 電動工具一般安全注意事項

**警告** 請詳讀工作臺及電動工具的所有安全警告與使用說明。若不遵照以下列出的指示，將可能導致電擊、著火和/或人員重傷。

保存所有警告和說明書以備查閱。

在所有警告中，「電動工具」此一名詞泛指：以市電驅動的（有線）電動工具或是以電池驅動的（無線）電動工具。

#### 工作場地的安全

- ▶ 保持工作場地清潔和明亮。混亂和黑暗的場地會引發事故。
- ▶ 不要在易爆環境，如有易燃液體、氣體或粉塵的環境下操作電動工具。電動工具產生的火花會點燃粉塵或氣體。
- ▶ 讓兒童和旁觀者離開後操作電動工具。注意力不集中會使您失去對工具的控制。

#### 電氣安全

- ▶ 電動工具插頭必須與插座相配。絕不能以任何方式改裝插頭。需接地的電動工具不能使用任何轉換插頭。未經改裝的插頭和相配的插座將減少電擊危險。
- ▶ 避免人體接觸接地表面，如管道、散熱片和冰箱。如果您身體接地會增加電擊危險。

- ▶ 不得將電動工具暴露在雨中或潮濕環境中。水進入電動工具將增加電擊危險。
- ▶ 不得濫用電線。絕不能用電線搬運、拉動電動工具或拔出其插頭。使電線遠離熱源、油、銳利邊緣或移動零件。受損或纏繞的軟線會增加電擊危險。
- ▶ 當在戶外使用電動工具時，使用適合戶外使用的延長線。適合戶外的軟線，將減少電擊危險。
- ▶ 如果在潮濕環境下操作電動工具是不可避免的，應使用剩餘電流動作保護器（RCD）。使用RCD可降低電擊危險。

#### 人身安全

- ▶ 保持警覺，當操作電動工具時關注所從事的操作並保持清醒。當您感到疲倦，或在有藥物、酒精或治療反應時，不要操作電動工具。在操作電動工具時瞬間的疏忽會導致嚴重人身傷害。
- ▶ 使用個人防護裝置。始終佩戴護目鏡。安全裝置，諸如適當條件下使用防塵面具、防滑安全鞋、安全帽、聽力防護等裝置能減少人身傷害。
- ▶ 防止意外起動。確保開關在連接電源和/或電池盒、拿起或搬運工具時處於關閉位置。手指放在已接通電源的開關上或開關處於接通時插入插頭可能會導致危險。
- ▶ 在電動工具接通之前，拿掉所有調節鑰匙或扳手。遺留在電動工具旋轉零件上的扳手或鑰匙會導致人身傷害。
- ▶ 手不要伸展得太長。時刻注意立足點和身體平衡。這樣在意外情況下能很好地控制電動工具。

- ▶ **著裝適當。** 不要穿寬鬆衣服或佩戴飾品。讓您的衣物及頭髮遠離運動部件。寬鬆衣服、佩飾或長髮可能會捲入運動部件中。
- ▶ 如果提供了與排屑、集塵設備連接用的裝置，要確保他們連接完好且使用得當。使用這些裝置可減少塵屑引起的危險。
- ▶ 切勿因經常使用工具所累積的熟練感而過度自信，輕忽工具的安全守則。任何一個魯莽的舉動都可能瞬間造成人員重傷。

#### 電動工具使用和注意事項

- ▶ **不要濫用電動工具，** 根據用途使用適當的電動工具。選用適當設計的電動工具會使您工作更有效、更安全。
- ▶ 如果開關不能開啟或關閉工具電源，則不能使用該電動工具。不能用開關來控制的電動工具是危險的且必須進行修理。
- ▶ 在進行任何調整、更換配件或貯存電動工具之前，必須從電源上拔掉插頭並/或取出電池盒。這種防護性措施將減少工具意外起動的危險。
- ▶ 將閒置不用的電動工具貯存在兒童所及範圍之外，並且不要讓不熟悉電動工具或對這些說明不瞭解的人操作電動工具。電動工具在未經培訓的用戶手中是危險的。
- ▶ 保養電動工具與配備。檢查運動部件是否調整到位或卡住，檢查零件破損情況和影響電動工具運行的其他狀況。如有損壞，電動工具應在使用前修理好。許多事故由維護不良的電動工具引發。
- ▶ 保持切削刀具鋒利和清潔。保養良好的有鋒利切削刃的刀具不易卡住而且容易控制。
- ▶ 按照使用說明書，考慮作業條件和進行的作業來使用電動工具、配件和工具的刀頭等。將電動工具用於那些與其用途不符的操作可能會導致危險。
- ▶ 把手及握持區應保持乾燥、潔淨，且不得沾染任何油液或油脂。易滑脫的把手及握持區將無法讓您在發生意外狀況時安全地抓緊並控制工具。

#### 檢修

- ▶ 將您的電動工具送交專業維修人員，必須使用同樣的備件進行更換。這樣將確保所維修的電動工具的安全性。

#### 鑽孔的安全警告

##### 所有作業的安全說明

- ▶ 進行作業時，負責進行切割的配件可能會碰觸到隱藏的配線或電動工具的電線，請從絕緣握把處拿持電動工具。負責進行切割的配件若是觸及「導電」電線，可能導致電動工具外露的金屬部件「導電」，進而使操作人員遭受電擊。

##### 使用長鑽頭的安全說明

- ▶ 切勿以超過鑽頭額定最高轉速的速度操作。若鑽頭未接觸工件且以超過最高轉速的速度無負載轉動，可能會讓鑽頭彎曲並導致人員受傷。

- ▶ 請務必以低速啟動並將鑽尖確實抵住工件。若鑽頭未接觸工件且以超過最高轉速的速度無負載轉動，可能會讓鑽頭彎曲並導致人員受傷。
- ▶ 請沿著鑽頭方向施加適當的壓力，切勿過度施壓。鑽頭可能會彎曲並造成斷裂、失控並導致人員受傷。

#### 其他安全注意事項

- ▶ **固定好工件。** 使用固定裝置或老虎鉗固定工件，會比用手持握工件更牢固。
- ▶ 如果嵌件工具被夾住了，請立刻關閉電動工具的電源。請準備好承受反作用力所造成的反彈。電動工具過載時或當它在進行加工的工件內部歪斜時，都會造成嵌件工具被夾住不動。
- ▶ 使用合適的偵測裝置偵察隱藏的電線，或者向當地的相關單位尋求支援。接觸電線可能引起火災並讓操作者觸電。若損壞瓦斯管會引起爆炸。鑿穿水管不僅會造成嚴重的財物損失，也可能導致觸電。
- ▶ 必須等待電動工具完全靜止後才能將它放下。嵌件工具可能卡住而使電動工具失控。

## 產品和功率描述



請詳讀所有安全注意事項和指示。如未遵守安全注意事項與指示，可能導致火災、人員遭受電擊及/或重傷。請留意操作說明書中最前面的圖示。

#### 依規定使用機器

本電動工具可以在木材、金屬、陶瓷和塑膠上鑽孔。具備電子調速和正逆轉功能的電動工具亦可用於拆裝螺栓及攻牙。

#### 插圖上的機件

機件的編號和電動工具詳解圖上的編號一致。

- (1) 快速夾頭<sup>A)</sup>
- (2) 前套筒
- (3) 後套筒
- (4) 腰帶夾
- (5) 把手 (絕緣握柄)
- (6) 起停開關鎖止按鈕
- (7) 起停開關
- (8) 正逆轉開關 (GBM 10 RE)
- (9) 夾頭扳手<sup>A)</sup>
- (10) 齒環式夾頭<sup>A)</sup>
- (11) 螺絲起子工具頭<sup>A)</sup>
- (12) 工具頭通用夾持器<sup>A)</sup>

A) 圖表或說明上提到的配件，並不包含在基本的供貨範圍中。本公司的配件清單中有完整的配件供應項目。



## 技術性數據

電鑽		GBM 10	GBM 10 RE	GBM 10 RE
產品機號		3 601 D73 0..	3 601 D73 5..	3 601 D73 6..
額定輸入功率	瓦	450	450	450
輸出功率	瓦	236	236	236
無負載轉速	次 / 分	2 600	0-2 600	0-2 600
額定轉速	次 / 分	1 760	0-1 760	0-1 760
額定扭力	牛頓米	14	14	14
主軸頸直徑	毫米	43	43	43
轉速調控		-	●	●
正逆轉功能		-	●	●
齒環式夾頭		●	●	-
快速夾頭		-	-	●
最大鑽孔直徑				
- 鋼材	毫米	10	10	10
- 木材	毫米	25	25	25
- 鋁材	毫米	10	10	10
夾頭的夾緊範圍	毫米	1-10	1-10	1-10
重量符合 EPTA-Procedure 01:2014	公斤	1.3	1.3	1.3
絕緣等級		□/	□/	□/

本說明書提供的參數是以 230 伏特為依據，於低電壓地區，此數據有可能不同。

## 安裝

- ▶ **維修電動工具或換裝零、配件之前，務必從插座上拔出插頭。**

### 更換工具

- ▶ **更換工具時請戴上防護手套。**長時間操作之後夾頭溫度會變得非常高。

#### 快速夾頭 (請參考圖 A)

請握住快速夾頭 (1) 的後套筒 (3) 不要讓它移動，然後沿旋轉方向 ① 旋轉前套筒 (2)，直到能夠將工具裝入。裝入工具。

請握住快速夾頭 (1) 的後套筒 (3) 不要讓它移動，然後徒手沿旋轉方向 ② 用力轉緊前套筒 (2)，直到不再聽見越過制動卡榫的軋軋聲。這樣才代表夾頭已自動上鎖。

取下工具時，當您反向旋轉前端套筒 (2)，此鎖止裝置便會自動重新解鎖。

#### 可自動上鎖的齒環式夾頭 (請參考圖 B)

透過旋轉方式，將齒環式夾頭 (10) 打開至能夠裝入工具為止。

裝入工具。將夾頭扳手 (9) 插進齒環式夾頭 (10) 的對應孔，然後均勻地施力將工具夾緊。

#### 螺栓拆裝工具 (請參考圖 C)

使用螺絲起子工具頭 (11) 時，請您務必使用工具頭通用夾持器 (12)。必須使用與螺絲頭大小相符的螺絲起子工具頭。

## 更換夾頭

如果電動工具本身沒有主軸鎖定功能，則更換夾頭的工作必須交給經授權的博世電動工具客戶服務中心來處理。



必須以約 31 - 35 Nm 的旋緊扭力將夾頭旋緊。

## 吸除廢塵 / 料屑

含鉛的顏料及部分木材、礦物和金屬的加工廢塵有害健康。機器操作者或者工地附近的人如果接觸，吸入這些廢塵，可能有過敏反應或者感染呼吸道疾病。

特定粉塵 (例如加工橡木或山毛櫸的廢塵) 可能致癌，特別是與處理木材的添加劑 (例如木材的防腐劑等) 混合之後。只有經過專業訓練的人才允許加工含石棉的物料。

- 工作場所要保持空氣流通。
- 建議佩戴 P2 濾網等級的口罩。

請留意並遵守貴國與加工物料有關的法規。

- ▶ **避免讓工作場所堆積過多的塵垢。**塵埃容易被點燃。

## 操作

### 操作機器

- ▶ **請注意電源電壓！**電源的電壓必須和電動工具銘牌上標示的電壓一致。標示為 230 V 的電動工具亦可接上 220 V 電源。

**設定旋轉方向 (GBM 10 RE) (請參考圖 D)**

透過正逆轉開關 (8) 即可變更電動工具的旋轉方向。但按下起停開關 (7) 時，將無法這樣做。

**正轉：**若要旋入螺栓及旋緊螺母，請將正逆轉開關 (8) 往左推到底。

**逆轉：**若要鬆開或旋出螺栓與螺母，請將正逆轉開關 (8) 往右推到底。

**啟動 / 關閉**

按下電源開關 (7) 不要放開，即可讓電動工具持續運轉。

若要讓起停開關 (7) 保持在壓下狀態，請按壓鎖止按鍵 (6)。

若要關閉電動工具，請直接放開起停開關 (7) 即可，或者您若有使用鎖止按鍵 (6)，則請在起停開關 (7) 上短按一下後放開。

**調整轉數 (GBM 10 RE)**

您可為已啟動的電動工具無段調控轉速，轉速是由按壓起停開關 (7) 的深度而定。

輕按起停開關 (7) 時，轉速較低。逐漸在開關上加壓，轉速也會跟著提高。

**作業注意事項**

▶ **維修電動工具或換裝零、配件之前，務必從插座上拔出插頭。**

▶ **電動工具應先停止運轉，然後才放到螺母 / 螺栓上。**轉動中的嵌件工具可能會滑開。

在金屬上鑽孔時，僅能使用完好的銳利 HSS 鑽頭 (HSS = 高速鋼)。選用博世原廠的配件產品，即可確保符合此品質等級。

利用鑽頭磨利器 (配件) 即可毫不費力地磨利直徑 2.5–10 mm 的麻花鑽頭。

進行精密鑽孔時，請使用鑽床架 (配件)。

虎鉗屬於配件，能夠牢牢地夾住工件。它可以避免工件滑動，並能夠防止因為工件走滑而發生的意外。

使用低轉速長期操作之後，應該讓電動工具以最大轉速空轉約 3 分鐘來幫助機器冷卻。

將較大、較長螺栓旋入堅硬材質之前，應先以螺紋孔底徑預鑽孔至 2/3 螺栓長度。

**腰帶夾**

使用腰帶夾 (4) 即可把電動工具掛在腰帶上。如此不但能夠空出雙手而且電動工具亦隨手可及。

**維修和服務****維修和清潔**

▶ **維修電動工具或換裝零、配件之前，務必從插座上拔出插頭。**

▶ **電動工具和通風口都必須保持清潔，這樣才能夠提高工作品質和安全性。**

如果必須更換連接線，請務必交由博世或者經授權的博世電動工具顧客服務執行，以避免危害機器的安全性能。

**顧客服務處和顧客諮詢中心**

本公司顧客服務處負責回答有關本公司產品的維修、維護和備用零件的問題。如需解圖和備件的資料，請至以下網頁：[www.bosch-pt.com](http://www.bosch-pt.com)

若對本公司產品及其配件有任何疑问，博世應用諮詢小組很樂意為您提供協助。

工匠與 DIY 玩家網路平台入口：[www.powertool-portal.de](http://www.powertool-portal.de)

當您需要諮詢或訂購備用零件時，請務必提供本產品銘牌上的 10 位零件編號。

**台灣**

台灣羅伯特博世股份有限公司

建國北路一段90 號6 樓

台北市10491

電話：(02) 2515 5388

傳真：(02) 2516 1176

[www.bosch-pt.com.tw](http://www.bosch-pt.com.tw)

**製造商地址：**

Robert Bosch Power Tools GmbH

羅伯特· 博世電動工具有限公司

70538 Stuttgart / GERMANY

70538 斯圖加特 / 德國

**廢棄物處理**

必須以符合環保的方式，回收再利用損壞的機器、配件和廢棄的包裝材料。



不可以把電動工具丟入一般的家庭垃圾中。

單元	設備名稱：電鑽，型號：GBM 10 RE 限用物質及其化學符號					
	鉛 (Pb)	汞 (Hg)	鎘 (Cd)	六價鉻 (Cr <sup>6+</sup> )	多溴聯苯 (PBB)	多溴二苯醚 (PBDE)
開關	0	0	0	0	0	0
電容器	0	0	0	0	0	0
馬達	0	0	0	0	0	0
電源線	0	0	0	0	0	0
外殼(塑料)	0	0	0	0	0	0

備考 1. "超出 0.1 wt %" 及 "超出 0.01 wt %" 係指限用物質之百分比含量超出百分比含量基準值。

備考 2. "0" 係指該項限用物質之百分比含量未超出百分比含量基準值。

備考 3. " - " 係指該項限用物質為排除項目。

## 한국어

### 안전 수칙

#### 전동공구 일반 안전 수칙

**⚠ 경고** 본 전동공구와 함께 제공된 모든 안전경고, 지시사항, 그림 및 사양을 숙지하십시오. 다음의 지시 사항을 준수하지 않으면 감전, 화재, 또는 심각한 부상을 초래할 수 있습니다.

**앞으로 참고할 수 있도록 이 안전수칙과 사용 설명서를 잘 보관하십시오.**

다음에서 사용되는 "전동공구"라는 개념은 전원에 연결하여 사용하는 (전선이 있는) 전동 기기나 배터리를 사용하는 (전선이 없는) 전동 기기를 의미합니다.

#### 작업장 안전

- ▶ 작업장을 항상 깨끗이 하고 조명을 밝게 하십시오. 작업장 환경이 어수선하거나 어두우면 사고를 초래할 수 있습니다.
- ▶ 가연성 유체, 가스 또는 분진이 있어 폭발 위험이 있는 환경에서 전동공구를 사용하지 마십시오. 전동공구는 분진이나 증기에 점화하는 스파크를 일으킬 수 있습니다.
- ▶ 전동공구를 사용할 때 구경꾼이나 어린이 혹은 다른 사람이 작업장에 접근하지 못하게 하십시오. 다른 사람이 주의를 산만하게 하면 기기에 대한 통제력을 잃기 쉽습니다.

#### 전기에 관한 안전

- ▶ 전동공구의 전원 플러그가 전원 콘센트에 잘 맞아야 합니다. 플러그를 절대 변경시켜서는 안 됩니다. (접지된) 전동공구를 사용할 때 어댑터 플러그를 사용하지 마십시오. 변형되지 않은 플러그와 잘 맞는 콘센트를 사용하면 감전의 위험을 줄일 수 있습니다.
- ▶ 파이프 관, 라디에이터, 레인지, 냉장고와 같은 접지 표면에 물이 닿지 않도록 하십시오. 몸에 닿을 경우 감전될 위험이 높습니다.
- ▶ 전동공구를 비에 맞지 않게 하고 습기 있는 곳에 두지 마십시오. 전동공구에 물이 들어가면 감전될 위험이 높습니다.
- ▶ 전원 코드를 잘못 사용하는 일이 없도록 하십시오. 전원 코드를 잡고 전동공구를 운반해서는 안 되며, 콘센트에서 전원 플러그를 뽑을 때 전원 코드를 잡아당겨서는 절대로 안 됩니다. 전원 코드가 열과 오일에 접촉하는 것을 피하고, 날카로운 모서리나 기기의 가동 부위에 닿지 않도록 주의하십시오. 손상되거나 영킨 전원 코드는 감전을 유발할 수 있습니다.

▶ 실외에서 전동공구로 작업할 때는 실외용으로 적당한 연장 전원 코드만을 사용하십시오. 실외용 연장 전원 코드를 사용하면 감전의 위험을 줄일 수 있습니다.

▶ 전동공구를 습기 찬 곳에서 사용해야 할 경우에는 누전 차단기를 사용하십시오. 누전 차단기를 사용하면 감전 위험을 줄일 수 있습니다.

#### 사용자 안전

- ▶ 신중하게 작업하며, 전동공구를 사용할 때 경솔하게 행동하지 마십시오. 피로한 상태이거나 약물 복용 및 음주한 후에는 전동공구를 사용하지 마십시오. 전동공구를 사용할 때 잠시라도 주의가 산만해지면 중상을 입을 수 있습니다.
- ▶ 작업자 안전을 위한 장치를 사용하십시오. 항상 보호 안경을 착용하십시오. 전동공구의 종류와 사용에 따라 먼지 보호 마스크, 미끄러지지 않는 안전화, 안전모 또는 귀마개 등의 안전한 복장을 하면 상해의 위험을 줄일 수 있습니다.
- ▶ 실수로 기기가 작동되지 않도록 주의하십시오. 전동공구를 전원에 연결하거나 배터리를 끼우기 전에, 혹은 기기를 들거나 운반하기 전에, 전원 스위치가 꺼져 있는지 다시 확인하십시오. 전동공구를 운반할 때 전원 스위치에 손가락을 대거나 전원 스위치가 켜진 상태에서 전원을 연결하면 사고 위험이 높습니다.
- ▶ 전동공구를 사용하기 전에 조절하는 툴이나 키 등을 빼 놓으십시오. 회전하는 부위에 있는 툴이나 키로 인해 상처를 입을 수 있습니다.
- ▶ 자신을 과신하지 마십시오. 불안정한 자세를 피하고 항상 평형을 이룬 상태로 작업하십시오. 안정된 자세와 평형한 상태로 작업해야만이 의외의 상황에서 전동공구를 안전하게 사용할 수 있습니다.
- ▶ 알맞은 작업복을 입으십시오. 헐렁한 복장을 하거나 장신구를 착용하지 마십시오. 머리카락이 가동하는 기기 부위에 가까이 닿지 않도록 주의하십시오. 헐렁한 복장, 장신구 혹은 긴 머리는 가동 부위에 말려 사고를 초래할 수 있습니다.
- ▶ 분진 추출장치나 수거장치의 조립이 가능한 경우, 이 장치가 연결되어 있는지, 제대로 작동이 되는지 확인하십시오. 이러한 분진 추출장치를 사용하면 분진으로 인한 사고 위험을 줄일 수 있습니다.
- ▶ 툴을 자주 사용한다고 해서 안주하는 일이 없게 하고 공구의 안전 수칙을 무시하지 않도록 하십시오. 부주의하게 취급하여 순간적으로 심각한 부상을 입을 수 있습니다.

#### 전동공구의 올바른 사용과 취급

- ▶ 기기를 과부하 상태에서 사용하지 마십시오. 작업할 때 이에 적당한 전동공구를 사용하십시오. 알맞은 전동공구를 사용하면 지정된 성능 한도 내에서 더 효율적으로 안전하게 작업할 수 있습니다.

- ▶ **전원 스위치가 고장 난 전동공구를 사용하지 마십시오.** 전원 스위치가 작동되지 않는 전동공구는 위험하므로, 반드시 수리를 해야 합니다.
- ▶ **전동공구를 조정하거나 액세서리 부품 교환 혹은 공구를 보관할 때, 항상 전원 콘센트에서 플러그를 미리 빼어 놓거나 배터리를 분리하십시오.** 이러한 조치는 실수로 전동공구가 작동하게 되는 것을 예방합니다.
- ▶ **사용하지 않는 전동공구는 어린이 손이 닿지 않는 곳에 보관하고, 전동공구 사용에 익숙지 않거나 이 사용 설명서를 읽지 않은 사람은 기기를 사용해서는 안 됩니다.** 경험이 없는 사람이 전동공구를 사용하면 위험합니다.
- ▶ **전동공구 및 액세서리를 조심스럽게 관리하십시오.** 가동 부위가 하자 없이 정상적인 기능을 하는지, 걸리는 부위가 있는지, 혹은 전동공구의 기능에 중요한 부품이 손상되지 않았는지 확인하십시오. 손상된 기기의 부품은 전동공구를 다시 사용하기 전에 반드시 수리를 맡기십시오. 제대로 관리하지 않은 전동공구의 경우 많은 사고를 유발합니다.
- ▶ **절단 공구를 날카롭고 깨끗하게 관리하십시오.** 날카로운 절단면이 있고 잘 관리된 절단공구는 걸리는 경우가 드물고 조절하기도 쉽습니다.
- ▶ **전동공구, 액세서리, 장착하는 공구 등을 사용할 때, 이 지시 사항과 특별히 기종 별로 나와있는 사용 방법을 준수하십시오.** 이때 작업 조건과 실시하려는 작업 내용을 고려하십시오. 원래 사용 분야가 아닌 다른 작업에 전동공구를 사용할 경우 위험한 상황을 초래할 수 있습니다.
- ▶ **손잡이 및 잡는 면을 건조하게 유지하고, 오일 및 그 리스가 묻어 있지 않도록 깨끗하게 하십시오.** 손잡이 또는 잡는 면이 미끄러우면 예상치 못한 상황에서 안전한 취급 및 제어가 어려워집니다.

#### 서비스

- ▶ **전동공구 수리는 반드시 전문 인력에게 맡기고, 수리 정비 시 보쉬 순정 부품만을 사용하십시오.** 그렇게 함으로써 기기의 안전성을 오래 유지할 수 있습니다.

#### 드릴 작업에 대한 안전 경고사항

##### 모든 작업에 대한 안전 수칙

- ▶ **절단용 액세서리가 숨겨진 배선 또는 코드를 접촉할 가능성이 있는 작업을 수행할 경우, 전동공구의 절연된 손잡이 면만 잡으십시오.** 절단용 액세서리가 "전류가 흐르는" 전선에 접촉되면, 전동공구의 노출된 금속 부품에 "전류가 흐르는" 상태로 만들어 작업자가 감전될 수 있습니다.

##### 긴드릴 비트를 사용할 경우 안전 수칙

- ▶ **절대 드릴 비트의 최대 정격 속도를 초과한 고속에서 작업하지 마십시오.** 고속으로 작업할 경우, 비트가 구부러져 가공물에 닿지 않은 상태에서 회전하면서 부상을 입을 수 있습니다.
- ▶ **드릴링 시에는 항상 낮은 속도에서 작업을 시작하여 비트의 끝이 가공물에 닿도록 하십시오.** 고속으로 작업할 경우, 비트가 구부러져 가공물에 닿지 않

은 상태에서도 회전하면서 부상을 입을 수 있습니다.

- ▶ **비트가 작동하는 부분에만 압력을 가하고 과도한 압력을 주지 마십시오.** 비트가 구부러져 파손되거나 통제력을 잃어 부상을 입을 수 있습니다.

#### 추가 안전 경고사항

- ▶ **작업물을 잘 고정하십시오.** 고정장치나 기계 바이스에 끼워서 작업하면 손으로 잡는 것보다 더 안전합니다.
- ▶ **틀 홀더에 끼워진 비트가 물리면 즉시 전동공구 스위치를 끄십시오.** 반동을 유발할 수 있는 강한 반동력이 생길 수 있습니다. 전동공구가 과부하된 상태이거나 또는 작업하려는 소재에 걸렸을 경우 비트가 물립니다.
- ▶ **보이지 않는 부위에 에너지 배선 및 배관 여부를 확인하려면 적당한 탐지기를 사용하거나 담당 전력 공급회사에 문의하십시오.** 전선에 접하게 되면 화재나 전기 충격을 야기할 수 있습니다. 가스관을 손상시키면 폭발 위험이 있습니다. 수도관을 파손하게 되면 재산 피해를 유발하거나 전기 충격을 야기할 수 있습니다.
- ▶ **전동공구를 내려놓기 전에 기기가 완전히 멈추었는지 확인하십시오.** 삽입공구가 걸리거나 전동공구에 대한 통제가 어려워질 수 있습니다.

#### 제품 및 성능 설명



**모든 안전 수칙과 지침을 숙지하십시오.** 다음의 안전 수칙과 지침을 준수하지 않으면 화재 위험이 있으며 감전 혹은 중상을 입을 수 있습니다.

사용 설명서 앞 부분에 제시된 그림을 확인하십시오.

#### 규정에 따른 사용

본 전동공구는 목재나 금속, 세라믹 그리고 플라스틱에 드릴 작업을 하는 데 사용해야 합니다. 전자식 속도 조절 및 역회전 기능이 있는 전동공구는 또한 스크류 작업 및 나사 가공에도 사용 가능합니다.

#### 제품의 주요 명칭

제품의 주요 명칭에 표기되어 있는 번호는 기기 그림이 나와있는 면을 참고하십시오.

- (1) 키레스 척<sup>A)</sup>
- (2) 앞쪽 솔리브
- (3) 뒤쪽 솔리브
- (4) 벨트 고정클립
- (5) 손잡이(절연된 손잡이 부위)
- (6) 전원 스위치 잠금 버튼
- (7) 전원 스위치
- (8) 회전방향 전환 스위치(GBM 10 RE)
- (9) 드릴척 키<sup>A)</sup>
- (10) 키 타입 척<sup>A)</sup>
- (11) 스크류 드라이버 비트<sup>A)</sup>

(12) 유니버설 비트 홀더<sup>A)</sup>

A) 도면이나 설명서에 나와있는 액세스리리는 표준 공급부품에 속하지 않습니다. 전체 액세스리리는 저희 액세스리리 프로그램을 참고하십시오.

제품 사양

드릴 머신		GBM 10	GBM 10 RE	GBM 10 RE
제품 번호		3 601 D73 0..	3 601 D73 5..	3 601 D73 6..
소비 전력	W	450	450	450
출력	W	236	236	236
무부하 속도	min <sup>-1</sup>	2600	0-2600	0-2600
정격 속도	min <sup>-1</sup>	1760	0-1760	0-1760
정격토크	Nm	14	14	14
스핀들 칼라 직경	mm	43	43	43
속도 제어		-	●	●
우측/좌측 회전		-	●	●
키타입 척		●	●	-
키레스 척		-	-	●
최대드릴 직경				
- 철재	mm	10	10	10
- 목재	mm	25	25	25
- 알루미늄	mm	10	10	10
드릴 척 클램핑 범위	mm	1-10	1-10	1-10
EPTA-Procedure 01:2014에 따른 중량	kg	1.3	1.3	1.3
보호 등급		□/	□/	□/

자료는 정격 전압 [U] 230V를 기준으로 한 것입니다. 전압이 다른 경우 및 국가별 사양에 따라 변동이 있을 수 있습니다.

조립

▶ 전동공구를 보수 정비하기 전에 반드시 콘센트에서 전원 플러그를 빼십시오.

액세서리의 교환

▶ 공구 교체 시 보호장갑을 착용하십시오. 장시간 작업을 하면 드릴 척이 과열될 수 있습니다.

키레스 척(그림 A 참조)

키레스 척 (1) 뒤쪽 슬리브 (3) 를 꼭 잡고 앞쪽 슬리브 (2) 를 비트가 끼워질 수 있을 정도까지 ❶ 회전 방향으로 돌리십시오. 공구를 끼우십시오.

키레스 척 (1) 뒤쪽 슬리브 (3) 를 꼭 잡고 앞쪽 슬리브 (2) 를 꼭 잡은 상태에서 더 이상 잠기는 소리가 나지 않을 때까지 앞쪽 슬리브 ❷ 회전 방향으로 힘껏 돌려 잠급니다. 이를 통해 드릴 척은 자동으로 잠깁니다. 비트를 빼기 위해 슬리브 앞부분 (2) 을 반대 방향으로 돌리면 잠금 상태가 다시 해제됩니다.

자동 잠금 장치가 달린 키타입 드릴 척(그림 B 참조)

공구가 삽입될 때까지 키타입 드릴 척 (10) 을 돌려 푸십시오.

비트를 끼우십시오. 드릴 척 키 (9) 를 키타입 드릴 척 (10) 의 해당 구멍에 끼우고 공구를 균일하게 조이십시오.

스크류 드라이버 비트(그림 C 참조)

스크류 드라이버 비트 (11) 사용 시 항상 유니버설 홀더 (12) 를 사용해야 합니다. 스크류 헤드에 맞는 스크류 드라이버 비트만 사용하십시오.

드릴 척 교환하기

드릴 스팀들 잠금 장치가 없는 전동공구의 경우, 드릴 척 교환은 보쉬 지정 전동공구 서비스 센터에 맡기십시오.



드릴 척은 대략 31- 35 Nm의 조임 토크로 조여야 합니다.

분진 및 톱밥 추출장치

납 성분을 포함한 페인트나 몇몇 나무 종류, 또는 광물 성분 그리고 철과 같은 재료의 분진은 건강을 해칠 수 있습니다. 이 분진을 만지거나 호흡할 경우, 사용자나 주변 사람들은 알레르기 반응이나 호흡기 장애를 일으킬 수 있습니다.

떡갈나무나 너도밤나무와 같은 특정한 분진은 암을 유발시키며, 특히 목재 처리용으로 사용되는 부가 원료(크로마트, 목재 보호제)와 혼합되면 암을 유발시키게 됩니다. 석면 성분을 포함한 재료는 오직 전문가가 작업을 해야 합니다.

- 작업장의 통풍이 잘 되도록 하십시오.

- 필터등급 P2에 해당하는 호흡 마스크를 사용하십시오.

작업용 재료에 관해 국가가 지정한 규정을 고려하십시오.

- ▶ **작업장에 분진이 쌓이지 않도록 하십시오.** 분진이 쉽게 발화할 수 있습니다.

## 작동

### 기계 시동

- ▶ **전원의 전압에 유의하십시오!** 공급되는 전원의 전압은 전동공구의 명판에 표기된 전압과 동일해야 합니다. 230 V로 표시된 전동공구는 220 V에서도 작동이 가능합니다.

#### 회전방향 설정하기(GBM 10 RE)(그림 D 참조)

회전방향 선택 스위치 (8)를 이용해 전동공구의 회전 방향을 변경할 수 있습니다. 전원 스위치 (7)가 눌린 상태에서는 변경할 수 없습니다.

**우회전:** 드릴 작업 및 볼트를 돌려 끼우려면 회전방향 선택 스위치 (8)를 좌측 끝까지 누르십시오.

**좌회전:** 볼트 및 너트를 풀거나 돌려 빼려면 회전방향 선택 스위치 (8)를 우측 끝까지 미십시오.

#### 전원 스위치 작동

전동공구를 작동하려면 전원 스위치 (7)를 누르고 누른 상태를 유지하십시오.

눌린 상태의 전원 스위치 (7)를 잠금 상태로 유지하려면 잠금 버튼 (6)을 누릅니다.

전동공구의 스위치를 끄려면 전원 스위치 (7)에서 손을 떼거나 잠금 버튼 (6)을 눌러 잠금 상태인 경우에는 전원 스위치 (7)를 잠깐 눌렀다가 다시 놓습니다.

#### 회전방향 설정하기(GBM 10 RE)

전원 스위치 (7)를 밀어 이동시키는 만큼 전원이 켜진 전동공구의 회전속도를 조절할 수 있습니다.

전원 스위치 (7)를 약간만 밀면 속도가 낮아집니다. 세게 누르면 속도가 빨라집니다.

### 사용 방법

- ▶ **전동공구를 보수 정비하기 전에 반드시 콘센트에서 전원 플러그를 빼십시오.**
- ▶ **전동공구의 스위치가 꺼진 상태에서만 볼트/너트에 대십시오.** 회전하는 드릴 비트가 미끄러질 수 있습니다.

금속에 드릴 작업을 할 경우에는 항상 하자가 없는 날 카로운 HSS 드릴 비트(HSS = 하이 스피드 스틸)만 사용하십시오. 보쉬 액세서리 프로그램은 이에 상응하는 품질을 보증합니다.

드릴 연마기(액세서리)를 이용해 직경이 2.5-10 mm 인트위스트 드릴을 쉽게 연마할 수 있습니다.

특히 정밀한 작업을 할 때는 드릴 스탠드(액세서리)를 사용하십시오.

액세서리로 구매할 수 있는 기계 바이스를 통해 작업물을 안전하게 클램핑할 수 있습니다. 이를 통해 작업물이 잘못 돌아가거나 이로 인해 발생할 수 있는 사고를 방지할 수 있습니다.

낮은 회전속도로 장시간 작업한 후에는 냉각을 위해 전동공구를 약 3분간 최대 회전속도로 공회전시키십시오.

경질 작업 소재에 크고 긴 스크류를 끼우기 전에, 나사산의 중심 직경으로 스크류 길이의 약 2/3에 해당하는 길이로 초기 드릴 작업을 하는 것이 좋습니다.

#### 벨트 고정클립

벨트 고정클립 (4)으로 이 전동공구를 벨트에 매달아 놓을 수 있습니다. 그러면 두 손을 자유로이 사용할 수 있으며 어느 때나 이 전동공구를 사용할 수 있습니다.

## 보수 정비 및 서비스

### 보수 정비 및 유지

- ▶ **전동공구를 보수 정비하기 전에 반드시 콘센트에서 전원 플러그를 빼십시오.**

- ▶ **안전하고 올바른 작동을 위하여 전동공구와 전동공구의 통풍구를 항상 깨끗이 하십시오.**

연결코드를 교환해야 할 경우 안전을 기하기 위해 보쉬사나 보쉬 지정 전동공구 서비스 센터에 맡겨야 합니다.

### AS 센터 및 사용 문의

AS 센터에서는 귀하 제품의 수리 및 보수정비, 그리고 부품에 관한 문의를 받고 있습니다. 대체 부품에 관한 분해 조립도 및 정보는 인터넷에서도 찾아 볼 수 있습니다 - [www.bosch-pt.com](http://www.bosch-pt.com)

보쉬 사용 문의 팀에서는 보쉬의 제품 및 해당 액세서리에 관한 질문에 기꺼이 답변 드릴 것입니다.

전문 작업자 및 개인 작업자를 위한 인터넷 포털 [www.powertool-portal.de](http://www.powertool-portal.de)도 참조할 수 있습니다.

문의나 대체 부품 주문 시에는 반드시 제품 네임 플레이트에 있는 10자리의 부품번호를 알려 주십시오.

콜센터  
080-955-0909

### 처리

기기와 액세서리 및 포장 등은 환경 친화적인 방법으로 재생할 수 있도록 분류하십시오.



전동공구를 가정용 쓰레기로 처리하지 마십시오!

## ไทย

### คำเตือนเพื่อความปลอดภัย

คำเตือนเพื่อความปลอดภัยทั่วไปสำหรับเครื่องมือไฟฟ้า

#### ⚠ คำเตือน

อ่านคำเตือนเพื่อความปลอดภัย คำแนะนำ ภาพประกอบ และข้อมูล

จำเพาะทั้งหมดที่จัดส่งมาพร้อมกับเครื่องมือไฟฟ้า

การไม่ปฏิบัติตามคำแนะนำทั้งหมดที่ระบุไว้ด้านล่างนี้อาจทำให้ถูกไฟฟ้าดูด เกิดไฟไหม้ และ/หรือได้รับบาดเจ็บอย่างร้ายแรง

#### เก็บรักษา ค่าเตือน และ คำสั่ง ทั้งหมด สำหรับ เปิดอ่าน ในภายหลัง

คำว่า "เครื่องมือไฟฟ้า" ในคำเตือนหมายถึง เครื่องมือไฟฟ้าของทานที่ทำงานด้วยพลังงานไฟฟ้าจากแหล่งจ่ายไฟหลัก (มีสายไฟฟ้า) และเครื่องมือไฟฟ้าที่ทำงานด้วยพลังงานไฟฟ้าจากแบตเตอรี่ (ไร้สาย)

#### ความปลอดภัยในสถานที่ทำงาน

- ▶ รักษาสถานที่ทำงานให้สะอาดและมีไฟส่องสว่างดี สถานที่ที่มีมืดหรือรุงรังนำมาซึ่งอุบัติเหตุ
- ▶ อย่าใช้เครื่องมือไฟฟ้าทำงานในสภาพบรรยากาศที่จุดติดไฟได้ เช่น ในที่ที่มีของเหลวไวไฟ ก๊าซ หรือฝุ่น เมื่อใช้เครื่องมือไฟฟ้าจะเกิดประกายไฟซึ่งอาจจุดฝุ่นหรือไอให้ลุกเป็นไฟได้
- ▶ ขณะใช้เครื่องมือไฟฟ้าทำงาน ต้องกันเด็กและผู้ยืนดูให้ออกห่าง การหันเหความสนใจอาจทำให้ท่านขาดการควบคุมเครื่องได้

#### ความปลอดภัยเกี่ยวกับไฟฟ้า

- ▶ ปลั๊กของเครื่องมือไฟฟ้าต้องเหมาะสมพอดีกับเต้าเสียบ อย่าดัดแปลงปลั๊กไม่ว่าในลักษณะใดๆ อย่างเด็ดขาด อย่าใช้ปลั๊กพ่วงต่อใดๆ กับเครื่องมือไฟฟ้าที่มีสายดิน ปลั๊กที่ไม่ดัดแปลงและเต้าเสียบที่เข้ากันช่วยลดความเสี่ยงจากการถูกไฟฟ้าดูด
- ▶ หลีกเลี่ยงอย่าให้ร่างกายสัมผัสกับพื้นผิวที่ต่อสายดินหรือลงกราวด์ไว้ เช่น ท่อ เครื่องทำความร้อน เตา และตู้เย็น จะเสี่ยงอันตรายจากการถูกไฟฟ้าดูดมาก ขึ้นหากกระแสไฟฟ้าวิ่งผ่านร่างกายของท่านลงดิน
- ▶ อย่าให้เครื่องมือไฟฟ้าถูกฝุ่นหรืออยู่ในสภาพเปียกชื้น หากน้ำเข้าไปในเครื่องมือไฟฟ้า จะเพิ่มความเสี่ยงจากการถูกไฟฟ้าดูด
- ▶ อย่าใช้สายไฟฟ้าในทางที่ผิด อย่าใช้สายไฟฟ้าเพื่อยก ดึง หรือถอดปลั๊กเครื่องมือไฟฟ้า กันสายไฟฟ้าออกจากความรอน น้ำมัน ขอบแหลมคม หรือชิ้นส่วนที่เคลื่อนที่ สายไฟฟ้าที่ชำรุดหรือพันกันยังเพิ่มความเสี่ยงจากการถูกไฟฟ้าดูด
- ▶ เมื่อใช้เครื่องมือไฟฟ้าทำงานกลางแจ้ง ให้ใช้สายไฟต่อที่เหมาะสมสำหรับการใช้งานกลางแจ้ง การใช้สายไฟต่อที่เหมาะสมสำหรับใช้งานกลางแจ้ง ช่วยลดอันตรายจากการถูกไฟฟ้าดูด
- ▶ หากไม่สามารถหลีกเลี่ยงการใช้เครื่องมือไฟฟ้าทำงานในสถานที่เปียกชื้นได้ ให้ใช้สวิตช์ตัดวงจรเมื่อเกิดการรั่วไหลของไฟฟ้าจากสายดิน (RCD) การใช้สวิตช์ตัดวงจรเมื่อเกิดการรั่วไหลของไฟฟ้าจากสายดินช่วยลดความเสี่ยงต่อการถูกไฟฟ้าดูด

#### ความปลอดภัยของบุคคล

- ▶ ท่านต้องอยู่ในสภาพเตรียมพร้อม ระมัดระวังในสิ่งที่ท่านกำลังทำอยู่ และมีสติขณะใช้เครื่องมือไฟฟ้าทำงาน อย่าใช้เครื่องมือไฟฟ้าขณะที่ท่านกำลังเหนื่อย หรืออยู่ภายใต้การครอบงำของฤทธิ์ของยาเสพติด

แอลกอฮอล์ และยา เมื่อใช้เครื่องมือไฟฟ้าทำงาน ในช่วงเวลาที่ท่านขาดความเอาใจใส่อาจทำให้บุคคลบาดเจ็บอย่างรุนแรงได้

- ▶ ใช้อุปกรณ์ปกป้องร่างกาย สวมแว่นตาป้องกันเสมอ อุปกรณ์ปกป้อง เช่น หน้ากากกันฝุ่น รองเทากันลื่น หมวกแข็ง หรือประภทกันเสียงดังที่ใช้ตามความเหมาะสมกับสภาพการทำงาน จะลดการบาดเจ็บทางร่างกาย
- ▶ ป้องกันการติดเครื่องโดยไม่ตั้งใจ ตรวจสอบให้แน่ใจว่าสวิตช์อยู่ในตำแหน่งปิดก่อนเชื่อมต่อเข้ากับแหล่งจ่ายไฟ และ/หรือแบตเตอรี่แพ็ค ยกหรือถือเครื่องมือถือเครื่องโดยใช้นิ้วหัวที่สวิตช์ หรือเสียบปลั๊กไฟในขณะที่สวิตช์เปิดอยู่ อาจนำไปสู่อุบัติเหตุที่ร้ายแรงได้
- ▶ นำเครื่องมือปรับแต่งหรือประแจปากตายออกก่อนเปิดสวิตช์เครื่องมือไฟฟ้า เครื่องมือหรือประแจปากตายที่วางอยู่กับส่วนของเครื่องที่กำลังหมุนจะทำให้บุคคลบาดเจ็บได้
- ▶ อย่าเอื้อมไกลเกินไป ตั้งที่ยืนที่มั่นคงและวางน้ำหนักให้สมดุลตลอดเวลา ในลักษณะที่ท่านสามารถควบคุมเครื่องมือไฟฟ้าในสถานการณ์ที่ไม่คาดคิดได้ดีกว่า
- ▶ แต่งกายอย่างเหมาะสม อย่าใส่เสื้อผ้าหลวมหรือสวมเครื่องประดับ เอาผมและเสื้อผ้าออกจากชิ้นส่วนที่เคลื่อนที่ เสื้อผ้าหลวม เครื่องประดับ และผมยาวอาจเข้าไปติดในชิ้นส่วนที่เคลื่อนที่
- ▶ หากเครื่องมือไฟฟ้ามีขอเชื่อมต่อกับเครื่องดูดฝุ่นหรือเครื่องเก็บผง ให้ตรวจสอบให้แน่ใจว่าได้เชื่อมต่อและใช้งานอย่างถูกต้อง การใช้อุปกรณ์ดูดฝุ่นช่วยลดอันตรายที่เกิดจากฝุ่นได้
- ▶ เมื่อใช้งานเครื่องมือบ่อยครั้งจะเกิดความคุ้นเคย อย่าให้ความคุ้นเคยทำให้ท่านเกิดความชะล่าใจและละเลยกฎเกณฑ์ด้านความปลอดภัยในการใช้งานเครื่อง การทำงานอย่างไม่ระมัดระวังอาจทำให้เกิดการบาดเจ็บอย่างร้ายแรงภายในเสี้ยววินาที

#### การใช้และการดูแลรักษาเครื่องมือไฟฟ้า

- ▶ อย่างฝืนกำลังเครื่องมือไฟฟ้า ใช้เครื่องมือไฟฟ้าที่ถูกต้องตรงตามลักษณะงานของท่าน เครื่องมือไฟฟ้าที่ถูกต้องจะทำงานได้ดีกว่าและปลอดภัยกว่าในระดับสมรรถภาพที่ออกแบบไว้
- ▶ อย่าใช้เครื่องมือไฟฟ้าถ้าสวิตช์ไม่สามารถเปิดปิดได้ เครื่องมือไฟฟ้าที่ไม่สามารถควบคุมการเปิดปิดด้วยสวิตช์ได้ เป็นเครื่องมือไฟฟ้าที่ไม่ปลอดภัยและต้องปลงซ่อมแซม
- ▶ กอนปรับแต่งเครื่อง เปลี่ยนอุปกรณ์ประกอบ หรือเก็บเครื่องเข้าที่ ต้องถอดปลั๊กออกจากแหล่งจ่ายไฟ และ/หรือถอดแบตเตอรี่แพ็คออกจากเครื่องมือไฟฟ้าหากถอดออกได้
- ▶ มาตรการป้องกันเพื่อความปลอดภัยนี้ช่วยลดความเสี่ยงจากการติดเครื่องโดยไม่ตั้งใจ
- ▶ เมื่อเลิกใช้งานเครื่องมือไฟฟ้า ให้เก็บเครื่องมือไว้ในที่ที่เด็กหยิบไม่ถึง และไม่อนุญาตให้บุคคลที่ไม่คุ้นเคยกับเครื่องหรือบุคคลที่ไม่ได้อ่านคำแนะนำเหล่านี้ใช้เครื่องมือไฟฟ้าเป็นของอันตรายหากตกอยู่ในมือของผู้ใช้ที่ไม่ได้รับการฝึกฝน
- ▶ บำรุงรักษาเครื่องมือไฟฟ้าและอุปกรณ์ประกอบ ตรวจสอบชิ้นส่วนที่เคลื่อนที่ต่างๆ ไม่ตรงแนวหรือติดขัดหรือไม่ ตรวจสอบการแตกหักของชิ้นส่วนและสภาพอื่นใดที่

อาจมีผลต่อการทำงานของเครื่องมือไฟฟ้า หากชำรุดต้องส่งเครื่องมือไฟฟ้าไปซ่อมแซมก่อนใช้งานอุบัติเหตุหลายอย่างเกิดขึ้นเนื่องจากดูแลรักษาเครื่องไม่ดีพอ

- ▶ **รักษาเครื่องมือตัดให้คมและสะอาด**  
หากบำรุงรักษาเครื่องมือที่มีขอบตัดแหลมคมอย่างถูกต้องจะสามารถตัดได้ลื่นไม่ติดขัดและควบคุมได้ง่ายกว่า
- ▶ **ใช้เครื่องมือไฟฟ้า อุปกรณ์ประกอบ เครื่องมือ และอุปกรณ์อื่นๆ ตรงตามคำแนะนำเหล่านี้ โดยคำนึงถึงเงื่อนไขการทำงานและงานที่จะทำ** การใช้เครื่องมือไฟฟ้าทำงานที่ต่างไปจากวัตถุประสงค์การใช้งานของเครื่อง อาจนำไปสู่สถานการณ์ที่เป็นอันตรายได้
- ▶ **ดูแลตามจับและพื้นผิวจับให้แห้ง สะอาด และปราศจากคราบน้ำมันและจาระบี** ตามจับและพื้นผิวจับที่ลื่นทำให้หยิบจับได้ไม่ปลอดภัยและไม่สามารถควบคุมเครื่องมือในสถานการณ์ที่ไม่คาดคิด

#### การบริการ

- ▶ **ส่งเครื่องมือไฟฟ้าของท่านเข้ารับบริการจากช่างซ่อมที่มีคุณสมบัติเหมาะสม โดยใช้ช่องที่เหมือนกันเท่านั้น** ในลักษณะนี้ท่านจะแน่ใจได้ว่าเครื่องมือไฟฟ้าอยู่ในสภาพที่ปลอดภัย

#### คำเตือนเพื่อความปลอดภัยสำหรับส่วน

##### คำเตือนเพื่อความปลอดภัยสำหรับการใช้งานทั้งหมด

- ▶ **เมื่อทำงานในบริเวณที่อุปกรณ์ตัดอาจสัมผัสสายไฟฟ้าที่ซ่อนอยู่หรือสายไฟฟ้าของตัวเครื่องเอง ต้องจับเครื่องมือไฟฟ้าตรงพื้นผิวจับทั้งหมดนั้น** หากเครื่องมือตัดสัมผัสสายที่ "มีกระแสไฟฟ้า" ไหลผ่าน จะทำให้ชิ้นส่วนโลหะที่ไม่ได้ออกแบบของเครื่องมือไฟฟ้าเกิด "มีกระแสไฟฟ้า" ด้วย และส่งผลให้ใช้งานเครื่องถูกไฟฟาดได้

##### คำเตือนเพื่อความปลอดภัยเมื่อใช้ดอกสว่านยาว

- ▶ **อย่าทำงานด้วยความเร็วที่สูงกว่าอัตราความเร็วสูงสุดของดอกสว่าน** ที่ความเร็วที่สูงกว่า ดอกสว่านอาจโค้งงอเมื่อปล่อยให้หมุนอย่างอิสระโดยไม่สัมผัสชิ้นงาน และส่งผลให้ได้รับบาดเจ็บทางร่างกาย
- ▶ **เริ่มต้นเจาะด้วยความเร็วต่ำและให้ปลายดอกสว่านสัมผัสชิ้นงานเสมอ** ที่ความเร็วที่สูงกว่า ดอกสว่านอาจโค้งงอเมื่อปล่อยให้หมุนอย่างอิสระโดยไม่สัมผัสชิ้นงาน และส่งผลให้ได้รับบาดเจ็บทางร่างกาย
- ▶ **ใช้แรงกดให้ตรงกับแนวดอกสว่านเท่านั้นและอย่าใช้แรงกดมากเกินไป** ไปดอกสว่านอาจโค้งงอทำให้แตกหักหรือสูญเสียการควบคุม และส่งผลให้ได้รับบาดเจ็บทางร่างกาย

##### คำแนะนำเพื่อความปลอดภัยเพิ่มเติม

- ▶ **ยึดชิ้นงานให้แน่น** การยึดชิ้นงานด้วยเครื่องมือหนีบหรือแท่นจับจะมั่นคงกว่าการยึดด้วยมือ
- ▶ **ปิดสวิตช์เครื่องมือไฟฟ้าทันทีหากเครื่องมือติดขัด ให้เตรียมพร้อมสำหรับปฏิกิริยาแรงบิดสูงซึ่งเป็นเหตุให้**

#### ข้อมูลทางเทคนิค

ส่วนไฟฟ้า	GBM 10	GBM 10 RE	GBM 10 RE
หมายเลขสินค้า	3 601 D73 0..	3 601 D73 5..	3 601 D73 6..
กำลังไฟฟ้าที่กักด้านเข้า	450	450	450

เกิดการตกลับ เครื่องมือจะติดขัดเมื่อเครื่องมือไฟฟ้าถูกใช้เกินกำลังหรือเครื่องมือถูกบีบอัดอยู่ในชิ้นงาน

- ▶ **ใช้เครื่องตรวจจับที่เหมาะสมเพื่อตรวจหาสายไฟฟ้าหรือท่อสารเคมีที่อาจซ่อนอยู่ในบริเวณทำงานหรือติดต่อบริษัทสารเคมีในพื้นที่เพื่อขอความช่วยเหลือ** การสัมผัสกับสายไฟฟ้าอาจทำให้เกิดไฟไหม้หรือถูกไฟฟาด การทำให้ออกแก๊สเสียหายนอาจทำให้เกิดระเบิด การเจาะเข้าในท่อน้ำทำให้ทรัพย์สินเสียหาย หรืออาจเป็นเหตุให้ถูกไฟฟาดได้
- ▶ **รอให้เครื่องมือไฟฟ้าหยุดสนิทก่อนวางเครื่องลงบนพื้น** เครื่องมือที่ใส่อยู่อาจติดขัดและทำให้สูญเสียการควบคุมเครื่องมือไฟฟ้า

#### รายละเอียดผลิตภัณฑ์และข้อมูลจำเพาะ



**อ่านคำเตือนเพื่อความปลอดภัยและคำแนะนำทั้งหมด** การไม่ปฏิบัติตามคำเตือนและคำสั่งอาจเป็นสาเหตุให้ถูกไฟฟาด เกิดไฟไหม้และ/หรือได้รับบาดเจ็บอย่างร้ายแรง กรุณาดูภาพประกอบในส่วนหน้าของคู่มือการใช้งาน

#### ประโยชน์การใช้งานของเครื่อง

เครื่องมือไฟฟ้านี้ใช้สำหรับเจาะในไม้ โลหะ เซรามิก และพลาสติก เครื่องที่มีระบบควบคุมอิเล็กทรอนิกส์และการหมุนซ้าย/ขวาสามารถไขชิ้นสกรูและทำเกลียวตัวผู้ได้ด้วย

#### ส่วนประกอบที่แสดงภาพ

ลำดับเลขของส่วนประกอบผลิตภัณฑ์อ้างอิงถึงส่วนประกอบของเครื่องที่แสดงในหน้าภาพประกอบ

- (1) หัวจับดอกชนิดจับเร็ว <sup>A)</sup>
- (2) ปลอกหน้า
- (3) ปลอกหลัง
- (4) คลิปเข็มขัด
- (5) ด้ามจับ (พื้นผิวจับหมุนวน)
- (6) ปุ่มล็อกให้สวิตช์เปิด-ปิดทำงาน
- (7) สวิตช์เปิด-ปิด
- (8) สวิตช์เปลี่ยนทิศทางการหมุน (GBM 10 RE)
- (9) ประแจหัวจับดอก <sup>A)</sup>
- (10) หัวจับดอกชนิดมีเฟืองใน <sup>A)</sup>
- (11) ดอกไขควง <sup>A)</sup>
- (12) ก้านจับดอกทั่วไป <sup>A)</sup>

A) อุปกรณ์ประกอบที่แสดงภาพหรืออธิบายไม่รวมอยู่ในการจัดส่งมาตรฐาน กรุณาดูอุปกรณ์ประกอบทั้งหมดในรายการแสดงอุปกรณ์ประกอบของเรา



ส่วนไฟฟ้า		GBM 10	GBM 10 RE	GBM 10 RE
กำลังไฟฟ้าออก	วัตต์	236	236	236
ความเร็วรอบเดินตัวเปล่า	รอบ/นาที	2 600	0-2 600	0-2 600
ความเร็วพิกัด	รอบ/นาที	1 760	0-1 760	0-1 760
แรงบิดพิกัด	นิวตันเมตร	14	14	14
เส้นผ่าศูนย์กลางปลอกเพลลา	มม.	43	43	43
การควบคุมความเร็วรอบ		-	●	●
การหมุนซ้าย/ขวา		-	●	●
หัวจับดอกชนิดมีเฟืองใน		●	●	-
หัวจับดอกชนิดจับเร็ว		-	-	●
Ø-การเจาะ				
- เหล็ก	มม.	10	10	10
- ไม้	มม.	25	25	25
- อะลูมิเนียม	มม.	10	10	10
วงหนีบหัวจับดอก	มม.	1-10	1-10	1-10
น้ำหนักตามระเบียบการ-EPTA-Procedure 01:2014	กก.	1.3	1.3	1.3
ระดับความปลอดภัย		☐/	☐/	☐/

ค่าที่ให้นำมาใช้ได้กับแรงดันไฟฟ้าอนินอล [U] 230 โวลต์ค่าเหล่านี้อาจเปลี่ยนแปลงไปสำหรับแรงดันไฟฟ้าที่แตกต่างกันและไม่เคลือบสำหรับเฉพาะประเทศ

## การติดตั้ง

### ▶ ดึงปลั๊กไฟออกจากเต้าเสียบก่อนปรับแต่งเครื่อง

### การเปลี่ยนเครื่องมือ

#### ▶ สวมถุงมือป้องกันอันตรายเมื่อเปลี่ยนเครื่องมือ หัวจับดอกจะร้อนจัดขึ้นได้เมื่อใช้เครื่องทำงานนานๆ

#### หัวจับดอกชนิดจับเร็ว (ดูภาพประกอบ A)

จับปลอกหลัง (3) ของหัวจับดอกชนิดจับเร็ว (1) ให้แน่นและหมุนปลอกหน้า (2) ไปในทิศทางหมุน ⚙ จนสามารถสอดเครื่องมือได้ ใส่เครื่องมือเข้า

จับปลอกหลัง (3) ของหัวจับดอกชนิดจับเร็ว (1) ให้แน่นและไขมือหมุนปลอกหน้า (2) ไปในทิศทางหมุน ⚙ จนไม่ได้ยินเสียงลงล็อกอีกต่อไป ในลักษณะนี้หัวจับดอกจะถูกล็อกโดยอัตโนมัติ

การล็อกจะถูกปลดอีกครั้งเมื่อท่านหมุนปลอกหน้า (2) ไปในทิศทางตรงกันข้ามเพื่อถอดเครื่องมือออก

#### หัวจับดอกชนิดมีเฟืองในที่มีล็อกอัตโนมัติ (ดูภาพประกอบ B)

เปิดหัวจับดอกชนิดมีเฟืองใน (10) โดยหมุนจนสามารถใส่เครื่องมือได้

ใส่เครื่องมือเข้าสอดประแจหัวจับดอก (9) เข้าในรูที่สอดคล้องกันบนหัวจับดอกชนิดมีเฟืองใน (10) และหนีบเครื่องมือเข้าเท่าๆ กัน

#### เครื่องมือขัน (ดูภาพประกอบ C)

เมื่อใช้ดอกไขควง (11) ควรใช้ตามจับดอกทั่วไป (12) ด้วยเสมอ ใช้ดอกไขควงที่มีขนาดพอดีกับหัวสกรูเท่านั้น

## การเปลี่ยนหัวจับดอก

หากเครื่องมือไฟฟ้าไม่มีตัวล็อกเพลลาส่วน ต้องส่งเครื่องให้ศูนย์บริการหลังการขายสำหรับเครื่องมือไฟฟ้า บอช ที่ได้รับมอบหมายเพื่อทำการเปลี่ยนหัวจับดอก



**ต้องขันหัวจับดอกเข้าให้แน่นด้วยแรงบิดการขันประมาณ 31-35 นิวตันเมตร**

## การดูแล/ขี้อื้อ

ฝุ่นที่ได้จากวัสดุ เช่น เคลือบผิวที่มีสารตะกั่ว ไม้ยางประเภทเรซาด และโลหะ อาจเป็นอันตรายต่อสุขภาพ การสัมผัสหรือการหายใจเอาฝุ่นเข้าไปอาจทำให้เกิดปฏิกิริยาแพ้ฝุ่น และ/หรือนำมาซึ่งโรคติดเชื้อระบบหายใจแก่ผู้ใช้เครื่องมือหรือผู้ที่ยืนอยู่ใกล้เคียง

ฝุ่นบางประเภท เช่น ฝุ่นไม้โอ๊ก หรือไม้บีช นับเป็นสารที่ทำให้เกิดมะเร็ง โดยเฉพาะอย่างยิ่งเมื่อผสมกับสารเติมแต่งเพื่อบำบัดไม้ (โครเมียม ผลิตภัณฑ์รักษาเนื้อไม้) สำหรับวัสดุที่มีแอสเบสทอสตองใหญ่เชี่ยวชาญทำงานเท่านั้น

- จัดสถานที่ทำงานให้มีการระบายอากาศที่ดี
- ขอแนะนำให้สวมหน้ากากป้องกันการติดเชื้อที่มีระดับ-ใส่กรอง P2

ปฏิบัติตามกฎหมายบังคับสำคัญอื่น ๆ ที่เกี่ยวกับวัสดุชิ้นงานที่บังคับใช้ในประเทศของท่าน

### ▶ ป้องกันการสะสมของฝุ่นในสถานที่ทำงาน

ฝุ่นสามารถถูกไหม้อย่างง่ายดาย

## การปฏิบัติงาน

### การเริ่มต้นปฏิบัติงาน

- ▶ ให้สังเกตแรงดันไฟฟ้า! แรงดันไฟฟ้าจากแหล่งจ่ายไฟฟ้าต้องมีค่าตรงกับค่าแรง

## ต้นไฟฟ้าที่ระบุไว้บนแผ่นป้ายติดเครื่อง เครื่องมือไฟฟ้าที่มีเครื่องหมาย 230 โวลต์ สามารถใช้งานกับ 220 โวลต์ ได้ด้วย

### การตั้งทิศทางทวน (GBM 10 RE) (ดูภาพประกอบ D)

ท่านสามารถเปลี่ยนทิศทางทวนของเครื่องมือไฟฟ้าได้ด้วยสวิตช์เปลี่ยนทิศทางทวน (8) อย่างไรก็ตาม หากสวิตช์เปิด-ปิด (7) ถูกกดอยู่ จะกลับทิศทางทวนไม่ได้

**การหมุนทวนขวา:** สำหรับการเจาะและการขันสกรูเข้า ให้กดสวิตช์เปลี่ยนทิศทางทวน (8) ไปทางซ้ายจนสุด

**การหมุนทวนซ้าย:** สำหรับคลายหรือหมุนสกรูและนอตออก ให้กดสวิตช์เปลี่ยนทิศทางทวน (8) ไปทางขวาจนสุด

### การเปิด-ปิดเครื่อง

**สตาร์ท** เครื่องมือไฟฟ้าโดยกดสวิตช์เปิด-ปิด (7) และกดค้างไว้

**ล็อค** สวิตช์เปิด-ปิด (7) ที่กดค้างไว้โดยกดปุ่มล็อค (6)

**ปิดเครื่อง** โดยปล่อยนิ้วจากสวิตช์เปิด-ปิด (7) หรือในกรณีที่ถูกล็อคด้วยปุ่มล็อค (6) อยู่ ให้กดสวิตช์เปิด-ปิด (7) สั้นๆ และปล่อยนิ้ว

### การปรับความเร็วรอบ (GBM 10 RE)

ท่านสามารถปรับความเร็วรอบของเครื่องมือไฟฟ้าที่เปิดสวิตช์อยู่ได้อย่างต่อเนื่องตามแรงกดมากน้อยบนสวิตช์เปิด-ปิด (7) การกดสวิตช์เปิด-ปิด (7) เมาจะให้ความเร็วรอบต่ำ การกดสวิตช์แรงยิ่งขึ้นจะให้ความเร็วรอบสูงขึ้น

### ข้อแนะนำในการทำงาน

▶ **ดึงปลั๊กไฟออกจากเต้าเสียบก่อนปรับแต่งเครื่อง**

▶ **จับเครื่องมือไฟฟ้าข้ามหัวสกรู/นอตเมื่อเครื่องปิดอยู่เท่านั้น** เครื่องมือที่หมุนอยู่อาจลื่นไถล

ให้ใช้เฉพาะดอกสว่าน HSS (HSS = high-speed steel) ที่ลับคมอย่างดีสำหรับเจาะโลหะ โพรแกรม-อุปกรณ์ประกอบ-บอช รับประกันคุณภาพที่เหมาะสม

ท่านสามารถลับคมดอกสว่านเกลียวชนิดขนาดเส้นผ่าศูนย์กลาง 2.5-10 มม. ได้อย่างง่ายดายด้วยอุปกรณ์ลับดอกสว่าน (อุปกรณ์ประกอบ)

ให้ใช้แท่นจับสว่าน (อุปกรณ์ประกอบ) เมื่อต้องทำงานที่ใช้ความเที่ยงตรงสูง

ปากกาจับชิ้นงาน ซึ่งมีให้เลือกซื้อเป็นอุปกรณ์ประกอบ ช่วยให้สามารถยึดหนีชิ้นงานได้อย่างปลอดภัย อุปกรณ์นี้ช่วยป้องกันไม่ให้ชิ้นงานหมุนไปมาและป้องกันอุบัติเหตุที่อาจเกิดขึ้น

หลังจากทำงานที่ความเร็วรอบต่ำเป็นเวลานาน ท่านควรเดินเครื่องมือไฟฟ้าตัวเปล่าที่ความเร็วสูงสุดเป็นเวลาประมาณ 3 นาทีเพื่อให้เครื่องเย็นลง

ก่อนขันสกรูตัวใหญ่กว่า ยาวกว่า เข้าในเบรคขัดแข็ง ท่านควรเจาะรูนำด้วยสว่านขนาดศูนย์กลางหลักของเกลียวลึกประมาณ 2/3 ของความยาวสกรู

### คลิปเข็มขัด

เมื่อใช้คลิปเข็มขัด (4) ท่านสามารถแขวนเครื่องมือไฟฟ้าได้. เช่น เขากับเข็มขัด จากนั้นท่านจะมีมือว่างทั้งสองข้าง และสามารถหยิบจับเครื่องมือไฟฟ้าได้ตลอดเวลา

## การบำรุงรักษาและการบริการ

### การบำรุงรักษาและการทำความสะอาด

▶ **ดึงปลั๊กไฟออกจากเต้าเสียบก่อนปรับแต่งเครื่อง**

▶ **เพื่อให้งานได้อย่างถูกต้องและปลอดภัย ต้องรักษาเครื่องและช่องระบายอากาศให้สะอาดอยู่เสมอ**

เมื่อจำเป็นต้องเปลี่ยนสายไฟฟ้า ให้ส่งเครื่องให้บริษัท บอช หรือศูนย์บริการลูกค้าสำหรับเครื่องมือไฟฟ้า บอช ที่ได้รับมอบหมายทำการเปลี่ยนไฟ เพื่อหลีกเลี่ยงอันตรายด้านความปลอดภัย

### การบริการหลังการขายและการให้คำปรึกษาการใช้งาน

ศูนย์บริการหลังการขายของเรายินดีตอบคำถามของท่านที่เกี่ยวกับการบำรุงรักษาและการซ่อมแซมผลิตภัณฑ์รวมทั้งเรื่องอะไหล่ ภาพแยกชิ้นและข้อมูลเกี่ยวกับอะไหล่ยังสามารถดูได้ใน: [www.bosch-pt.com](http://www.bosch-pt.com)

ทีมงานที่ปรึกษาของ บอช ยินดีให้ข้อมูลเกี่ยวกับผลิตภัณฑ์ของเราและอุปกรณ์ประกอบต่างๆ

[www.powertool-portal.de](http://www.powertool-portal.de) เว็บไซต์สำหรับช่างฝีมือและช่างสมัครเล่น

เมื่อต้องการสอบถามและสั่งซื้ออะไหล่ กรุณาแจ้งหมายเลขสินค้า 10 หลักบนแผ่นป้ายรุ่นของผลิตภัณฑ์ทุกครั้ง

### ไทย

ไทย บริษัท โรเบิร์ต บอช จำกัด

เอพวยโอ เซ็นเตอร์ อาคาร 1 ชั้น 5

เลขที่ 2525 ถนนพระราม 4

แขวงคลองเตย เขตคลองเตย

กรุงเทพฯ 10110

โทร: +66 2012 8888

แฟกซ์: +66 2064 5800

[www.bosch.co.th](http://www.bosch.co.th)

ศูนย์บริการซ่อมและฝึกอบรม บอช

อาคาร ลาซาลทาวเวอร์ ชั้น G ห้องเลขที่ 2

บ้านเลขที่ 10/11 หมู่ 16

ถนนศรีนครินทร์

ตำบลบางแก้ว อำเภอบางพลี

จังหวัดสมุทรปราการ 10540

ประเทศไทย

โทรศัพท์ 02 7587555

โทรสาร 02 7587525

### การกำจัดขยะ

เครื่องมือไฟฟ้า อุปกรณ์ประกอบ และหีบห่อ ต้องนำไปแยกประเภทวัสดุเพื่อการรีไซเคิลที่เป็นมิตรต่อสิ่งแวดล้อม

อย่าทิ้งเครื่องมือไฟฟ้าลงในขยะครัวเรือน!



## Bahasa Indonesia

### Petunjuk Keselamatan

#### Petunjuk keselamatan umum untuk perkakas listrik

**⚠ PERINGATAN** Baca semua peringatan, petunjuk, ilustrasi, dan spesifikasi

keselamatan yang diberikan bersama perkakas listrik ini. Kesalahan dalam menjalankan petunjuk di bawah ini dapat mengakibatkan sengatan listrik, kebakaran, dan/atau cedera serius.

**Simpanlah semua peringatan dan petunjuk untuk penggunaan di masa mendatang.**

Istilah "perkakas listrik" dalam peringatan mengacu pada perkakas listrik yang dioperasikan dengan listrik (menggunakan kabel) atau perkakas listrik yang dioperasikan dengan baterai (tanpa kabel).

#### Keamanan tempat kerja

- ▶ **Jaga kebersihan dan pencahayaan area kerja.** Area yang berantakan atau gelap dapat memicu kecelakaan.
- ▶ **Jangan mengoperasikan perkakas listrik di lingkungan yang dapat memicu ledakan, seperti adanya cairan, gas, atau debu yang mudah terbakar.** Perkakas listrik dapat memancarkan bunga api yang kemudian mengakibatkan debu atau uap terbakar.
- ▶ **Jauhkan dari jangkauan anak-anak dan pengamat saat mengoperasikan perkakas listrik.** Gangguan dapat menyebabkan hilangnya kendali.

#### Keamanan listrik

- ▶ **Steker perkakas listrik harus sesuai dengan stopkontak. Jangan pernah memodifikasi steker. Jangan menggunakan steker adaptor bersama dengan perkakas listrik yang terhubung dengan sistem grounding.** Steker yang tidak dimodifikasi dan stopkontak yang cocok akan mengurangi risiko sengatan listrik.
- ▶ **Hindari kontak badan dengan permukaan yang terhubung dengan sistem grounding, seperti pipa, radiator, kompor, dan lemari es.** Terdapat peningkatan risiko terjadinya sengatan listrik jika badan Anda terhubung dengan sistem grounding.
- ▶ **Perkakas listrik tidak boleh terpapar hujan atau basah.** Air yang masuk ke dalam perkakas listrik menambah risiko terjadinya sengatan listrik.
- ▶ **Jangan menyalahgunakan kabel. Jangan gunakan kabel untuk membawa, menarik, atau melepas steker perkakas listrik. Jauhkan kabel dari panas, minyak, tepi yang tajam, atau komponen yang bergerak.** Kabel listrik yang rusak atau tersangkut menambah risiko terjadinya sengatan listrik.
- ▶ **Saat mengoperasikan perkakas listrik di luar ruangan, gunakan kabel ekstensi yang sesuai untuk penggunaan di luar ruangan.** Penggunaan kabel yang

cocok untuk pemakaian di luar ruangan mengurangi risiko terjadinya sengatan listrik.

- ▶ **Jika perkakas listrik memang harus dioperasikan di tempat yang lembap, gunakan pemutus arus listrik residu (RCD).** Penggunaan RCD akan mengurangi risiko terjadinya sengatan listrik.

#### Keselamatan personel

- ▶ **Tetap waspada, perhatikan aktivitas yang sedang dikerjakan dan gunakan akal sehat saat mengoperasikan perkakas listrik. Jangan gunakan perkakas listrik saat mengalami kelelahan atau di bawah pengaruh narkoba, alkohol, atau obat-obatan.** Jika perkakas listrik dioperasikan dengan daya konsentrasi yang rendah, hal tersebut dapat menyebabkan cedera serius.
- ▶ **Gunakan peralatan pelindung diri. Selalu kenakan pelindung mata.** Penggunaan perlengkapan pelindung seperti penutup telinga, helm, sepatu anti licin, dan masker debu akan mengurangi cedera.
- ▶ **Hindari start yang tidak disengaja. Pastikan switch berada di posisi off sebelum perkakas listrik dihubungkan ke sumber daya listrik dan/atau baterai, diangkat, atau dibawa.** Membawa perkakas listrik dengan jari menempel pada tombol atau perkakas listrik dalam keadaan hidup dapat memicu kecelakaan.
- ▶ **Singkirkan kunci penyetel atau kunci pas sebelum menghidupkan perkakas listrik.** Perkakas atau kunci pas yang masih menempel pada komponen perkakas listrik yang berputar dapat menyebabkan cedera.
- ▶ **Jangan melampaui batas. Berdirilah secara mantap dan selalu jaga keseimbangan.** Hal ini akan memberikan kontrol yang lebih baik terhadap perkakas listrik pada situasi yang tak terduga.
- ▶ **Kenakan pakaian dengan wajar. Jangan mengenakan perhiasan atau pakaian yang longgar. Jauhkan rambut dan pakaian dari komponen yang bergerak.** Pakaian yang longgar, rambut panjang, atau perhiasan dapat tersangkut dalam komponen yang bergerak.
- ▶ **Jika disediakan perangkat untuk sambungan pengisapan debu dan alat pengumpulan, pastikan perangkat tersebut terhubung dan digunakan dengan benar.** Penggunaan alat pengumpulan dapat mengurangi bahaya yang disebabkan oleh debu.
- ▶ **Jangan berpuas diri dan mengabaikan prinsip keselamatan karena terbiasa mengoperasikan perkakas.** Tindakan yang kurang hati-hati dapat mengakibatkan cedera serius dalam waktu sepersekian detik.

#### Penggunaan dan pemeliharaan perkakas listrik

- ▶ **Jangan memaksakan perkakas listrik. Gunakan perkakas listrik yang sesuai untuk pekerjaan yang dilakukan.** Perkakas listrik yang sesuai akan bekerja dengan lebih baik dan aman sesuai tujuan penggunaan.
- ▶ **Jangan gunakan perkakas listrik dengan switch yang tidak dapat dioperasikan.** Perkakas listrik yang

switchnya yang tidak berfungsi dapat menimbulkan bahaya dan harus diperbaiki.

- ▶ **Lepaskan steker dari sumber listrik dan/atau lepas baterai, jika dapat dilepaskan dari perkakas listrik sebelum menyetel, mengganti aksesoris, atau menyimpan perkakas listrik.** Tindakan preventif akan mengurangi risiko menghidupkan perkakas listrik secara tidak disengaja.
- ▶ **Jauhkan dan simpan perkakas listrik dari jangkauan anak-anak dan jangan biarkan orang-orang yang tidak mengetahui cara menggunakan perkakas listrik, mengoperasikan perkakas listrik.** Perkakas listrik dapat membahayakan jika digunakan oleh orang-orang yang tidak terlatih.
- ▶ **Lakukan pemeliharaan perkakas listrik dan aksesoris. Periksa komponen yang bergerak apabila tidak lurus atau terikat, kerusakan komponen, dan kondisi lain yang dapat mengganggu pengoperasian perkakas listrik. Apabila rusak, perbaiki perkakas listrik sebelum digunakan.** Kecelakaan sering terjadi karena perkakas listrik tidak dirawat dengan baik.
- ▶ **Jaga ketajaman dan kebersihan alat.** Alat pemotong dengan pisau pemotong yang tajam dan dirawat dengan baik tidak akan mudah tersangkut dan lebih mudah dikendalikan.
- ▶ **Gunakan perkakas listrik, aksesoris, dan komponen perkakas dll sesuai dengan petunjuk ini, dengan mempertimbangkan kondisi kerja dan pekerjaan yang akan dilakukan.** Penggunaan perkakas listrik untuk tujuan berbeda dari fungsinya dapat menyebabkan situasi yang berbahaya.
- ▶ **Jaga gagang dan permukaan genggam agar tetap kering, bersih, dan bebas dari minyak dan lemak.** Gagang dan permukaan genggam yang licin tidak menjamin keamanan kerja dan kontrol alat yang baik pada situasi yang tidak terduga.

#### Servis

- ▶ **Minta teknisi berkualifikasi untuk menyervis perkakas listrik dengan hanya menggunakan suku cadang yang identik.** Dengan demikian, hal ini akan memastikan keamanan perkakas listrik.

#### Petunjuk Keselamatan untuk Mengebor

##### Petunjuk keselamatan untuk semua pengoperasian

- ▶ **Pegang perkakas listrik pada permukaan gagang isolator saat digunakan karena aksesoris pemotong dapat saja bersentuhan dengan kabel yang tidak terlihat atau kabelnya sendiri.** Aksesoris pemotong yang bersentuhan dengan kabel yang dialiri listrik dapat menyebabkan bagian logam perkakas listrik yang terbuka dialiri listrik sehingga berisiko mengakibatkan sengatan listrik pada operator.

##### Petunjuk keselamatan saat menggunakan mata bor panjang

- ▶ **Jangan pernah mengoperasikan alat dengan kecepatan yang lebih tinggi dari nilai kecepatan**

**maksimal mata bor.** Pada kecepatan yang tinggi, mata bor akan membengkok jika berputar secara bebas tanpa menyentuh benda kerja dan dapat menyebabkan cedera terhadap pengguna.

- ▶ **Selalu hidupkan alat bor pada kecepatan rendah dengan ujung mata bor menyentuh benda kerja.** Pada kecepatan yang tinggi, mata bor akan membengkok jika berputar secara bebas tanpa menyentuh benda kerja dan dapat menyebabkan cedera terhadap pengguna.
- ▶ **Tekan hanya pada garis langsung dengan mata bor dan jangan tekan secara berlebihan.** Mata bor dapat membengkok dan menyebabkan kerusakan atau hilang kendali sehingga menyebabkan cedera terhadap pengguna.

#### Petunjuk Keselamatan tambahan

- ▶ **Gunakan alat kerja dengan aman.** Benda yang ditahan dalam alat pemegang atau bais lebih aman daripada benda yang dipegang dengan tangan.
- ▶ **Segera matikan perkakas listrik jika alat tambahan terkunci. Bersiaplah dengan reaksi tinggi yang menyebabkan sentakan.** Alat tambahan akan terkunci jika perkakas listrik mengalami kelebihan beban atau perkakas bergerak miring pada benda kerja.
- ▶ **Gunakanlah alat detektor logam yang cocok untuk mencari kabel dan pipa yang tidak terlihat atau hubungi perusahaan pengadaan setempat.** Sentuhan dengan kabel-kabel listrik dapat mengakibatkan api dan kontak listrik. Pipa gas yang rusak dapat mengakibatkan ledakan. Pipa air yang rusak mengakibatkan kerusakan barang-barang atau dapat mengakibatkan kontak listrik.
- ▶ **Sebelum meletakkan perkakas listrik, tunggulah hingga perkakas berhenti berputar.** Alat kerja dapat tersangkut dan menyebabkan perkakas listrik tidak dapat dikendalikan.

## Spesifikasi produk dan performa



**Bacalah semua petunjuk keselamatan dan petunjuk penggunaan.** Kesalahan dalam menjalankan petunjuk keselamatan dan petunjuk penggunaan dapat mengakibatkan kontak listrik, kebakaran, dan/atau luka-luka

yang berat.

Perhatikan ilustrasi yang terdapat pada sisi sampul panduan pengoperasian.

#### Tujuan penggunaan

Perkakas listrik ini cocok untuk mengebor kayu, logam, keramik, dan bahan sintetis. Perkakas listrik dengan pengendalian secara elektronik dan arah putaran ke kanan/kiri juga cocok untuk menyekrup dan mentap.

#### Ilustrasi komponen

Nomor-nomor dari bagian-bagian perkakas pada gambar sesuai dengan gambar perkakas listrik pada halaman bergambar.

- |  |   |
|--|---|
| <ul style="list-style-type: none"> <li>(1) Keyless chuck <sup>A)</sup></li> <li>(2) Selongsong depan</li> <li>(3) Selongsong belakang</li> <li>(4) Jepitan tempat menggantungkan</li> <li>(5) Gagang (genggaman isolator)</li> <li>(6) Tombol pengunci untuk tombol on/off</li> <li>(7) Tombol on/off</li> </ul> | <ul style="list-style-type: none"> <li>(8) Switch arah putaran (GBM 10 RE)</li> <li>(9) Kunci chuck <sup>A)</sup></li> <li>(10) Keyed chuck <sup>A)</sup></li> <li>(11) Mata obeng <sup>A)</sup></li> <li>(12) Dudukan bit universal <sup>A)</sup></li> </ul> <p>A) Aksesori yang ada pada gambar atau yang dijelaskan tidak termasuk dalam lingkup pengiriman standar. Semua aksesori yang ada dapat Anda lihat dalam program aksesori kami.</p> |
|--|---|

## Data teknis

Mesin bor		GBM 10	GBM 10 RE	GBM 10 RE
Nomor seri		3 601 D73 0..	3 601 D73 5..	3 601 D73 6..
Input daya nominal	W	450	450	450
Daya output	W	236	236	236
Kecepatan idle	min <sup>-1</sup>	2 600	0-2 600	0-2 600
Kecepatan nominal	min <sup>-1</sup>	1 760	0-1 760	0-1 760
Torsi nominal	Nm	14	14	14
Diameter leher spindel	mm	43	43	43
Pengendalian kecepatan putaran		-	●	●
Perputaran arah ke kanan/kiri		-	●	●
Keyed chuck		●	●	-
Keyless chuck		-	-	●
Ø (diameter) pengeboran maks				
- Baja	mm	10	10	10
- Kayu	mm	25	25	25
- Aluminium	mm	10	10	10
Rentang penjepitan chuck	mm	1-10	1-10	1-10
Berat sesuai dengan EPTA-Procedure 01:2014	kg	1,3	1,3	1,3
Klasifikasi keamanan		□/II	□/II	□/II

Data-data berlaku untuk tegangan nominal [U] 230 V. Pada tegangan yang lebih rendah dan pada model khusus mancanegara data-data ini bisa berlainan.

## Cara memasang

- ▶ **Sebelum mulai dengan pekerjaan pada perkakas listrik, tariklah steker dari stopkontak.**

### Mengganti alat

- ▶ **Pakai sarung tangan pelindung saat mengganti alat sisipan.** Chuck bor bisa menjadi sangat panas jika digunakan dalam waktu yang lama.

#### Keyless chuck (lihat gambar A)

Tahan selongsong belakang (3) keyless chuck (1) lalu putar selongsong depan (2) ke arah ① hingga alat dapat dipasang. Pasang alat.

Tahan selongsong belakang (3) keyless chuck (1) lalu putar selongsong depan (2) ke arah ② dengan kuat menggunakan tangan hingga tidak terdengar lagi tekanan. Kepala bor terkunci secara otomatis.

Penguncian akan terbuka kembali, jika selongsong depan diputar (2) ke arah yang berlawanan untuk melepaskan alat kerja.

#### Keyed chuck dengan pengunci otomatis (lihat gambar B)

Buka keyed chuck (10) dengan cara diputar hingga alat dapat dipasang.

Pasang alat sisipan. Pasang kunci chuck (9) lubang keyed chuck (10) yang sesuai dan kencangkan alat dengan teratur.

#### Obeng (lihat gambar C)

Saat menggunakan mata obeng (11) gunakan selalu dudukan bit universal (12). Hanya gunakan mata obeng yang sesuai dengan kepala sekrup.

## Mengganti chuck bor

Pada perkakas listrik tanpa pengunci spindel bor, penggantian chuck bor harus dilakukan oleh layanan pelanggan resmi untuk perkakas listrik Bosch.



**Chuck bor harus dikencangkan dengan torsi pengencangan sekitar 31 - 35 Nm.**

## Ekstraksi debu/serbuk

Debu dari bahan-bahan seperti cat yang mengandung timbel (timah hitam), beberapa jenis kayu, bahan mineral dan logam dapat berbahaya bagi kesehatan. Menyentuh atau menghirup debu-debu ini dapat mengakibatkan reaksi alergi dan/atau penyakit saluran pernapasan pada pengguna atau orang yang berada di dekatnya.

Beberapa debu tertentu seperti debu kayu pohon quercus atau pohon fagus silvatica dianggap dapat mengakibatkan penyakit kanker, terutama dalam campuran dengan bahan-bahan tambahan untuk pengolahan kayu (kromat, obat pengawet kayu). Bahan-bahan yang mengandung asbestos hanya boleh dikerjakan oleh orang-orang yang ahli.

- Perhatikanlah supaya ada pertukaran udara yang baik di tempat kerja.
- Kami anjurkan Anda memakai masker anti debu dengan filter kelas P2.

Taatilah peraturan-peraturan untuk bahan-bahan yang dikerjakan yang berlaku di negara Anda.

- ▶ **Hindari debu yang banyak terkumpul di tempat kerja.** Debu dapat tersulut dengan mudah.

## Penggunaan

### Cara penggunaan

- ▶ **Perhatikan tegangan listrik! Tegangan jaringan listrik harus sesuai dengan tegangan listrik yang tercantum pada label tipe perkakas listrik. Perkakas listrik dengan daya sebesar 230 V seperti yang diindikasikan pada label dapat juga dioperasikan pada daya 220 V.**

### Mengatur arah putaran (GBM 10 RE) (lihat gambar D)

Arah putaran perkakas listrik dapat diubah dengan switch pengubah arah (8). Hal tersebut tidak dapat dilakukan jika tombol on/off (7) ditekan.

**Searah jarum jam:** Untuk mengebor dan menyekrup, tekan switch arah putaran (8) ke kiri hingga maksimal.

**Berlawanan arah jarum jam:** Untuk mengendurkan atau melepas sekrup dan mur, tekan switch pengubah arah (8) ke kanan hingga maksimal.

### Mengaktifkan/menonaktifkan perkakas listrik

Untuk **menggunakan pertama kali** perkakas listrik, tekan dan tahan tombol on/off (7).

Untuk **mengunci** tombol on/off yang ditekan, (7) tekan tombol pengunci (6).

Untuk **menonaktifkan** perkakas listrik, lepaskan tombol on/off (7) jika tombol dikunci dengan tombol pengunci (6), tekan singkat tombol on/off (7) dan lepaskan.

### Mengatur kecepatan putaran (GBM 10 RE)

Kecepatan perkakas listrik yang diaktifkan dapat disetel terus-menerus bergantung seberapa kuat tombol on/off (7) ditekan.

Jika tombol on/off (7) ditekan singkat dan tidak terlalu kuat, kecepatan putaran akan menjadi rendah. Tekanan yang lebih besar mengakibatkan kecepatan putaran yang lebih tinggi.

### Petunjuk pengoperasian

- ▶ **Sebelum mulai dengan pekerjaan pada perkakas listrik, tarikh steker dari stopkontak.**
- ▶ **Pasang perkakas listrik pada mur/sekrup hanya saat dalam keadaan mati.** Alat sisipan yang berputar dapat tergelincir.

Hanya gunakan mata bor HSS yang diasah (HSS=high performance superspeed steel) untuk pengeboran logam. Kualitas terkait dijamin oleh program aksesoris Bosch.

Dengan alat pengasah mata bor (aksesori), bor berbentuk spiral dengan diameter 2,5–10 mm dapat diasah dengan mudah.

Untuk pengerjaan yang memerlukan ketelitian khusus, gunakan standar mesin bor (aksesori).

Benda kerja dapat dijepit dengan aman menggunakan ragum yang disediakan sebagai aksesoris. Alat ini akan mencegah benda yang dikerjakan bergeser dan terbalik dan menimbulkan kecelakaan.

Setelah digunakan dalam waktu yang lama dengan kecepatan rendah, biarkan perkakas listrik beroperasi dengan putaran maksimal pada kecepatan idle sekitar 3 menit agar menjadi dingin..

Sebelum memutar masuk sekrup yang besar dan panjang ke dalam bahan yang keras, buat lubang bor terlebih dulu dengan diameter inti ulir sekitar 2/3 dari panjang sekrup.

### Jepitan tempat menggantungkan

Dengan jepitan tempat menggantungkan (4), perkakas listrik dapat digantung misalnya pada satu tali pengikat. Dengan demikian Anda tidak perlu memegang perkakas listrik dan perkakas listrik tetap berada di dekat Anda.

## Perawatan dan servis

### Perawatan dan pembersihan

- ▶ **Sebelum mulai dengan pekerjaan pada perkakas listrik, tarikh steker dari stopkontak.**
- ▶ **Perkakas listrik dan lubang ventilasi harus selalu dibersihkan agar perkakas dapat digunakan dengan baik dan aman.**

Jika kabel listrik harus diganti, pekerjaan ini harus dilakukan oleh Bosch atau Service Center untuk perkakas listrik Bosch yang resmi, agar keselamatan kerja selalu terjamin.

### Layanan pelanggan dan konsultasi penggunaan

Layanan pelanggan Bosch menjawab semua pertanyaan Anda tentang reparasi dan perawatan serta tentang suku cadang produk ini. Gambaran teknis (exploded view) dan

informasi mengenai suku cadang dapat ditemukan di:

**www.bosch-pt.com**

Tim konsultasi penggunaan Bosch akan membantu Anda menjawab pertanyaan seputar produk kami beserta aksesorinya.

**www.powertool-portal.de**, portal internet untuk perajin dan tukang.

Jika Anda hendak menanyakan sesuatu atau memesan suku cadang, selalu sebutkan nomor model yang terdiri atas 10 angka dan tercantum pada label tipe produk.

### Indonesia

PT Robert Bosch  
Palma Tower 10th Floor  
Jalan RA Kartini II-S Kaveling 6  
Pondok Pinang, Kebayoran Lama  
Jakarta Selatan 12310  
Tel.: (021) 3005 5800  
Fax: (021) 3005 5801  
E-Mail: boschpowertools@id.bosch.com  
www.bosch-pt.co.id

### Cara membuang

Perkakas listrik, aksesoris, dan kemasan sebaiknya didaur ulang secara ramah lingkungan.



Jangan membuang perkakas listrik ke dalam sampah rumah tangga!

## Tiếng Việt

### Hướng dẫn an toàn

#### Hướng dẫn an toàn chung cho dụng cụ điện

**⚠ CẢNH BÁO** Hãy đọc toàn bộ các cảnh báo an toàn, hướng dẫn, hình ảnh và thông số kỹ thuật được cung cấp cho dụng cụ điện cầm tay này. Không tuân thủ mọi hướng dẫn được liệt kê dưới đây có thể bị điện giật, gây cháy và /hay bị thương tật nghiêm trọng. **Hãy giữ tất cả tài liệu về cảnh báo và hướng dẫn để tham khảo về sau.**

Thuật ngữ "dụng cụ điện cầm tay" trong phần cảnh báo là để cập đến sự sử dụng dụng cụ điện cầm tay của bạn, loại sử dụng điện nguồn (có dây cắm điện) hay vận hành bằng pin (không dây cắm điện).

#### Khu vực làm việc an toàn

- ▶ **Giữ nơi làm việc sạch và đủ ánh sáng.** Nơi làm việc bừa bộn và tối tăm dễ gây ra tai nạn.
- ▶ **Không vận hành dụng cụ điện cầm tay trong môi trường dễ gây nổ, chẳng hạn như nơi có chất lỏng dễ cháy, khí đốt hay rác.** Dụng cụ

điện cầm tay tạo ra các tia lửa nên có thể làm rác bén cháy hay bốc khói.

- ▶ **Không để trẻ em hay người đến xem đứng gần khi vận hành dụng cụ điện cầm tay.** Sự phân tâm có thể gây ra sự mất điều khiển.

#### An toàn về điện

- ▶ **Phích cắm của dụng cụ điện cầm tay phải thích hợp với ổ cắm. Không bao giờ được cải biến lại phích cắm dưới mọi hình thức. Không được sử dụng phích tiếp hợp nối tiếp đất (dây mát).** Phích cắm nguyên bản và ổ cắm đúng loại sẽ làm giảm nguy cơ bị điện giật.
- ▶ **Tránh không để thân tiếp xúc với đất hay các vật có bề mặt tiếp đất như đường ống, lò sưởi, hàng rào và tủ lạnh.** Có nhiều nguy cơ bị điện giật hơn nếu cơ thể bạn bị tiếp hay nối đất.
- ▶ **Không được để dụng cụ điện cầm tay ngoài mưa hay ở tình trạng ẩm ướt.** Nước vào máy sẽ làm tăng nguy cơ bị điện giật.
- ▶ **Không được lạm dụng dây dẫn điện. Không bao giờ được nắm dây dẫn để xách, kéo hay rút phích cắm dụng cụ điện cầm tay. Không để dây gần nơi có nhiệt độ cao, dầu nhớt, vật nhọn bén và bộ phận chuyển động.** Làm hỏng hay cuộn rối dây dẫn làm tăng nguy cơ bị điện giật.
- ▶ **Khi sử dụng dụng cụ điện cầm tay ngoài trời, dùng dây nối thích hợp cho việc sử dụng ngoài trời.** Sử dụng dây nối thích hợp cho việc sử dụng ngoài trời làm giảm nguy cơ bị điện giật.
- ▶ **Nếu việc sử dụng dụng cụ điện cầm tay ở nơi ẩm ướt là không thể tránh được, dùng thiết bị ngắt mạch tự động (RCD) bảo vệ nguồn.** Sử dụng thiết bị ngắt mạch tự động RCD làm giảm nguy cơ bị điện giật.

#### An toàn cá nhân

- ▶ **Hãy tỉnh táo, biết rõ mình đang làm gì và hãy sử dụng ý thức khi vận hành dụng cụ điện cầm tay. Không sử dụng dụng cụ điện cầm tay khi đang mệt mỏi hay đang bị tác động do chất gây nghiện, rượu hay dược phẩm gây ra.** Một thoáng mất tập trung khi đang vận hành dụng cụ điện cầm tay có thể gây thương tích nghiêm trọng cho bản thân.
- ▶ **Sử dụng trang bị bảo hộ cá nhân. Luôn luôn đeo kính bảo vệ mắt.** Trang bị bảo hộ như khẩu trang, giày chống trượt, nón bảo hộ, hay dụng cụ bảo vệ tai khi được sử dụng đúng nơi đúng chỗ sẽ làm giảm nguy cơ thương tật cho bản thân.
- ▶ **Phòng tránh máy khởi động bất ngờ. Bảo đảm công tắc máy ở vị trí tắt trước khi cắm vào nguồn điện và/hay lắp pin vào, khi nhắc máy lên hay khi mang xách máy.** Ngáng ngón tay vào công tắc máy để xách hay kích hoạt dụng cụ điện cầm tay khi công tắc ở vị trí mở dễ dẫn đến tai nạn.

- ▶ **Lấy mọi chìa hay khóa điều chỉnh ra trước khi mở điện dụng cụ điện cầm tay.** Khóa hay chìa còn gắn dính vào bộ phận quay của dụng cụ điện cầm tay có thể gây thương tích cho bản thân.
  - ▶ **Không rướn người. Luôn luôn giữ tư thế đứng thích hợp và thăng bằng.** Điều này tạo cho việc điều khiển dụng cụ điện cầm tay tốt hơn trong mọi tình huống bất ngờ.
  - ▶ **Trang phục thích hợp. Không mặc quần áo rộng lung tung hay mang trang sức. Giữ tóc và quần áo xa khỏi các bộ phận chuyển động.** Quần áo rộng lung tung, đồ trang sức hay tóc dài có thể bị cuốn vào các bộ phận chuyển động.
  - ▶ **Nếu có các thiết bị đi kèm để nối máy hút bụi và các phụ kiện khác, bảo đảm các thiết bị này được nối và sử dụng tốt.** Việc sử dụng các thiết bị gom hút bụi có thể làm giảm các độc hại liên quan đến bụi gây ra.
  - ▶ **Không để thói quen do sử dụng thường xuyên dụng cụ khiến bạn trở nên chủ quan và bỏ qua các quy định an toàn dụng cụ.** Một hành vi bất cẩn có thể gây ra thương tích nghiêm trọng chỉ trong tích tắc.
- Sử dụng và bảo dưỡng dụng cụ điện cầm tay**
- ▶ **Không được ép máy. Sử dụng dụng cụ điện cầm tay đúng loại theo đúng ứng dụng của bạn.** Dụng cụ điện cầm tay đúng chức năng sẽ làm việc tốt và an toàn hơn theo đúng tiến độ mà máy được thiết kế.
  - ▶ **Không sử dụng dụng cụ điện cầm tay nếu như công tắc không tắt và mở được.** Bất kỳ dụng cụ điện cầm tay nào mà không thể điều khiển được bằng công tắc là nguy hiểm và phải được sửa chữa.
  - ▶ **Rút phích cắm ra khỏi nguồn điện và/hay pin ra khỏi dụng cụ điện cầm tay nếu có thể tháo được, trước khi tiến hành bất kỳ điều chỉnh nào, thay phụ kiện, hay cất dụng cụ điện cầm tay.** Các biện pháp ngăn ngừa như vậy làm giảm nguy cơ dụng cụ điện cầm tay khởi động bất ngờ.
  - ▶ **Cất giữ dụng cụ điện cầm tay không dùng tới nơi trẻ em không lấy được và không cho người chưa từng biết dụng cụ điện cầm tay hay các hướng dẫn này sử dụng dụng cụ điện cầm tay.** Dụng cụ điện cầm tay nguy hiểm khi ở trong tay người chưa được chỉ cách sử dụng.
  - ▶ **Bảo quản dụng cụ điện cầm tay và các phụ kiện.** Kiểm tra xem các bộ phận chuyển động có bị sai lệch hay kẹt, các bộ phận bị rạn nứt và các tình trạng khác có thể ảnh hưởng đến sự vận hành của máy. Nếu bị hư hỏng, phải sửa chữa máy trước khi sử dụng. Nhiều tai

nạn xảy ra do bảo quản dụng cụ điện cầm tay tồi.

- ▶ **Giữ các dụng cụ cất bên và sạch.** Bảo quản đúng cách các dụng cụ cất có cạnh cất bên làm giảm khả năng bị kẹt và dễ điều khiển hơn.
- ▶ **Sử dụng dụng cụ điện cầm tay, phụ kiện, đầu cài v. v., đúng theo các chỉ dẫn này, hãy lưu ý đến điều kiện làm việc và công việc phải thực hiện.** Sự sử dụng dụng cụ điện cầm tay khác với mục đích thiết kế có thể tạo nên tình huống nguy hiểm.
- ▶ **Giữ tay cầm và bề mặt nắm luôn khô ráo, sạch sẽ và không dính dầu mỡ.** Tay cầm và bề mặt nắm trơn trượt không đem lại thao tác an toàn và kiểm soát dụng cụ trong các tình huống bất ngờ.

#### Bảo dưỡng

- ▶ **Đưa dụng cụ điện cầm tay của bạn đến thợ chuyên môn để bảo dưỡng, chỉ sử dụng phụ tùng đúng chủng loại để thay.** Điều này sẽ đảm bảo sự an toàn của máy được giữ nguyên.

#### Cảnh báo An toàn cho Máy khoan

##### Hướng dẫn an toàn cho mọi hoạt động

- ▶ **Chỉ cầm dụng cụ điện tại các bề mặt cầm nắm có cách điện, khi thực hiện một thao tác tại vị trí mà phụ kiện cắt có thể tiếp xúc với dây điện ngầm hoặc chính dây điện của thiết bị.** Phụ kiện cắt tiếp xúc với dây có điện có thể làm cho các phần kim loại hở của dụng cụ điện cầm tay có điện và có thể gây ra điện giật cho người vận hành.

##### Hướng dẫn an toàn khi sử dụng các mũi khoan dài

- ▶ **Không vận hành ở tốc độ cao hơn tốc độ tối đa cho phép của mũi khoan.** Ở tốc độ cao hơn, mũi khoan có thể bị cong nếu cho phép xoay tự do mà không cho tiếp xúc với phôi gia công, dẫn đến thương tích cho người.
- ▶ **Luôn khởi động khoan ở tốc độ thấp và với đầu mũi khoan tiếp xúc với phôi gia công.** Ở tốc độ cao hơn, mũi khoan có thể bị cong nếu cho phép xoay tự do mà không cho tiếp xúc với phôi gia công, dẫn đến thương tích cho người.
- ▶ **Chỉ dùng áp lực vào đường trực tiếp bằng mũi khoan và không dùng áp lực dư.** Các mũi khoan có thể cong, gãy gãy hoặc mất kiểm soát, dẫn đến thương tích cho người.

##### Các cảnh báo phụ thêm

- ▶ **Kẹp chặt vật gia công.** Vật gia công được kẹp bằng một thiết bị kẹp hay bằng ê-tô thì vững chắc hơn giữ bằng tay.
- ▶ **Tắt dụng cụ điện ngay nếu phụ tùng bị chặn.** Hãy chuẩn bị cho những mô-men phản ứng cao, mà gây ra sự dội ngược. Phụ tùng bị



chặn, nếu dụng cụ điện bị quá tải hoặc bị kẹt trong phôi gia công cần gia công.

- ▶ **Dùng thiết bị dò tìm thích hợp để xác định nếu có các công trình công cộng lắp đặt ngầm trong khu vực làm việc hay liên hệ với Cty công trình công cộng địa phương để nhờ hỗ trợ.** Đụng chạm đường dẫn điện có thể gây ra hỏa hoạn và điện giật. Làm hư hại đường dẫn khí ga có thể gây nổ. Làm thủng đường dẫn nước gây hư hỏng tài sản hay có khả năng gây ra điện giật.
- ▶ **Luôn luôn đợi cho máy hoàn toàn ngừng hẳn trước khi đặt xuống.** Dụng cụ lắp vào máy có thể bị kẹp chặt dẫn đến việc dụng cụ điện cầm tay bị mất điều khiển.

## Mô Tả Sản Phẩm và Đặc Tính Kỹ Thuật



**Đọc kỹ mọi cảnh báo an toàn và mọi hướng dẫn.** Không tuân thủ mọi cảnh báo và hướng dẫn được liệt kê dưới đây có thể bị điện giật, gây cháy và / hay bị thương tật nghiêm trọng.

Xin lưu ý các hình minh hoạt trong phần trước của hướng dẫn vận hành.

## Sử dụng đúng cách

Máy được thiết kế để khoan gỗ, kim loại, gốm và nhựa mú. Máy có trang bị bộ phận điện tử kiểm soát tốc độ và quay được chiều phải/trái cũng thích hợp để bắt vít và cắt ren.

## Các bộ phận được minh họa

Sự đánh số các biểu trưng của sản phẩm là để tham khảo hình minh họa của máy trên trang hình ảnh.

- (1) Đầu cặp mũi khoan tự động <sup>A)</sup>
- (2) Khớp vòng ngoài
- (3) Khớp vòng trong
- (4) Móc cài dây thắt lưng
- (5) Tay nắm (bề mặt nắm cách điện)
- (6) Nút khoá giữ chế độ tự-chạy của công tắc Tắt/Mở
- (7) Công tắc Tắt/Mở
- (8) Gạc vận chuyển đổi chiều quay (GBM 10 RE)
- (9) Khóa chốt kẹp mũi khoan <sup>A)</sup>
- (10) Đầu cặp mũi khoan vành răng <sup>A)</sup>
- (11) Chia vận vít <sup>A)</sup>
- (12) Ống cặp mũi khoan vận năng <sup>A)</sup>

A) Phụ tùng được trình bày hay mô tả không phải là một phần của tiêu chuẩn hàng hóa được giao kèm theo sản phẩm. Bạn có thể tham khảo tổng thể các loại phụ tùng, phụ kiện trong chương trình phụ tùng của chúng tôi.

## Thông số kỹ thuật

Khoan xoay		GBM 10	GBM 10 RE	GBM 10 RE
Mã số máy		<b>3 601 D73 0..</b>	<b>3 601 D73 5..</b>	<b>3 601 D73 6..</b>
Công suất vào danh định	W	450	450	450
Công suất ra	W	236	236	236
Tốc độ không tải	min <sup>-1</sup>	2 600	0–2 600	0–2 600
Tốc độ danh định	min <sup>-1</sup>	1 760	0–1 760	0–1 760
Lực vận danh định	Nm	14	14	14
Đường kính cổ trục	mm	43	43	43
Điều khiển tốc độ		–	●	●
Quay Phải/Trái		–	●	●
Mâm Cặp Khoan Dùng Khóa		●	●	–
Mâm Cặp Không Dùng Khóa		–	–	●
Ø lỗ khoan tối đa				
– Thép	mm	10	10	10
– Gỗ	mm	25	25	25
– Nhôm	mm	10	10	10
Phạm vi mâm cặp kẹp được	mm	1–10	1–10	1–10
Trọng lượng theo Qui trình EPTA-Procedure 01:2014	kg	1,3	1,3	1,3

Khoan xoay	GBM 10	GBM 10 RE	GBM 10 RE
Cấp độ bảo vệ	□/II	□/II	□/II

Các giá trị đã cho có hiệu lực cho điện thế danh định [U] 230 V. Đối với điện thế thấp hơn và các loại máy dành riêng cho một số quốc gia, các giá trị này có thể thay đổi.

## Sự lắp vào

- ▶ **Trước khi tiến hành bất cứ việc gì trên máy, kéo phích cắm điện nguồn ra.**

### Thay Dụng Cụ

- ▶ **Hãy mang găng tay bảo vệ khi thay dụng cụ.**  
Mâm cặp có thể trở nên rất nóng trong suốt thời gian dài liên tục hoạt động.

#### Đầu cặp mũi khoan tự động (xem hình A)

Giữ chặt khớp vòng trong (3) của đầu cặp mũi khoan tự động (1) và xoay khớp vòng ngoài (2) theo hướng ➊ cho đến khi có thể lắp được dụng cụ. Lắp dụng cụ vào.

Giữ chặt khớp vòng trong (3) của đầu cặp mũi khoan tự động (1) và xoay khớp vòng ngoài bằng tay (2) theo hướng ➋ thật mạnh cho đến khi không còn nghe thấy tiếng clic nữa. Bằng cách đó, đầu cặp mũi khoan sẽ tự động được khóa.

Cơ cấu khóa sẽ mở ra khi bạn xoay khớp vòng ngoài (2) theo hướng ngược lại để tháo dụng cụ.

#### Đầu cặp mũi khoan vành răng có khóa tự động (xem hình B)

Hãy mở đầu cặp mũi khoan vành răng (10) bằng cách vặn cho đến khi có thể lắp được dụng cụ. Lắp dụng cụ vào. Cắm khóa chốt kẹp mũi khoan (9) vào lỗ tương ứng của đầu cặp mũi khoan vành răng (10) và đồng thời kẹp chặt dụng cụ.

#### Dụng cụ vặn vít (xem hình C)

Khi sử dụng đầu gài vặn vít (11), bạn cần phải dùng ống lồng đa năng (12). Chỉ sử dụng đầu gài vặn vít vừa với đầu vít.

### Thay đầu cặp mũi khoan

Đối với máy không có khóa trực, mâm cặp khoan khi cần thay phải thông qua một đại lý phục vụ dụng cụ điện sau khi bán do Bosch ủy nhiệm.



**Đầu cặp mũi khoan phải được xiết chặt bằng mô-men xoắn khoảng 31 – 35 Nm.**

### Hút Dăm/Bụi

Mạt bụi từ các vật liệu được sơn phủ ngoài có chứa chì trên một số loại gỗ, khoáng vật và kim loại có thể gây nguy hại đến sức khoẻ con người. Dụng cụ chạm hay hít thở các bụi này có thể làm người sử dụng hay đứng gần bị dị ứng và/hoặc gây nhiễm trùng hệ hô hấp.

Một số mặt bụi cụ thể, ví dụ như bụi gỗ sỏi hay đầu, được xem là chất gây ung thư, đặc biệt là có liên quan đến các chất phụ gia dùng xử lý gỗ (chất

chromat, chất bảo quản gỗ). Có thể chỉ nên để thợ chuyên môn gia công các loại vật liệu có chứa amiăng.

- Tạo không khí thông thoáng nơi làm việc.
- Khuyến nghị nên mang mặt nạ phòng độc có bộ lọc cấp P2.

Tuân thủ các qui định của quốc gia bạn liên quan đến loại vật liệu gia công.

- ▶ **Tránh không để rác tích tụ tại nơi làm việc.**  
Rác có thể dễ dàng bắt lửa.

## Vận Hành

### Bắt Đầu Vận Hành

- ▶ **Hãy cẩn thận với nguồn điện! Điện thế nguồn phải đúng với điện thế đã ghi rõ trên nhãn máy. Dụng cụ điện được ghi 230 V cũng có thể được vận hành ở 220 V.**

#### Điều chỉnh hướng xoay (GBM 10 RE) (xem hình D)

Với gạc vặn chuyển đổi chiều quay (8) bạn có thể thay đổi hướng xoay của dụng cụ điện. Tuy nhiên, việc này không thực hiện được khi công tắc Tắt/Mở được nhấn (7).

**Quay phải:** Để khoan hay bắt vít, đẩy gạc vặn chuyển đổi chiều quay (8) sang trái đến cỡ chặn.

**Xoay ngược chiều kim đồng hồ:** Để nới lỏng hoặc tháo các vít và đai ốc hãy nhấn gạc vặn chuyển đổi chiều quay (8) sang bên phải cho tới cỡ chặn.

#### Bật/Tắt

Để **vận hành thử** dụng cụ điện hãy nhấn công tắc Tắt/Mở (7) và nhấn giữ.

Để **khóa** công tắc bật/tắt đã nhấn (7) hãy nhấn nút khóa giữ (6).

Để **tắt** dụng cụ điện, hãy nhả công tắc bật/tắt (7) hoặc nếu nó được khóa bằng nút khóa giữ (6), hãy nhấn nhanh công tắc bật/tắt (7) và nhả.

#### Điều chỉnh tốc độ vòng quay (GBM 10 RE)

Bạn có thể điều tiết liên tục số vòng quay của dụng cụ điện đã bật, tùy vào việc bạn nhấn công tắc Tắt/Mở như thế nào (7).

Nhấn nhẹ trên công tắc Tắt/Mở (7) sẽ kích hoạt số vòng quay thấp. Tăng lực nhấn lên công tắc làm tăng tốc độ quay.

### Hướng Dẫn Sử Dụng

- ▶ **Trước khi tiến hành bất cứ việc gì trên máy, kéo phích cắm điện nguồn ra.**

► **Chỉ đặt dụng cụ điện đã tắt lên đai ốc/vít.**

Dụng cụ đang quay có thể bị tuột ra.

Chỉ sử dụng mũi khoan HSS (HSS=thép gió) sắc và không bị lỗi. Chất lượng đáp ứng chuẩn được đảm bảo trong chương trình phụ kiện của Bosch.

Với thiết bị mài mũi khoan (phụ kiện), bạn có thể làm sắc mũi khoan xoắn có đường kính từ 2,5–10 mm một cách nhẹ nhàng.

Chúng tôi khuyên nên sử dụng giá khoan (xem phần phụ kiện) cho các công việc đặt biệt yêu cầu cần có độ chính xác cao.

Bàn kẹp máy, phụ kiện loại có thể mua được, đảm bảo sự kẹp vật gia công được chắc chắn. Điều này ngăn không làm cho vật gia công bị xoay và không bị tai nạn có thể xảy ra do sự cố này.

Sau một thời gian làm việc dài với tốc độ vòng quay thấp, bạn cần cho dụng cụ điện quay không tải với tốc độ tối đa trong khoảng 3 phút để làm mát.

Trước khi bắt một vít lớn, dài hơn bình thường vào vật liệu cứng, nên khoan trước một lỗ môi có cùng đường kính răng vít vào sâu vào khoảng 2/3 của chiều dài vít.

**Móc cài dây thắt lưng**

Với móc cài dây thắt lưng (4), bạn có thể treo dụng cụ điện, ví dụ, vào đai lưng. Sau đó bạn sẽ có hai tay tự do và dụng cụ điện sẽ luôn luôn dễ sử dụng.

## Bảo Dưỡng và Bảo Quản

### Bảo Dưỡng Và Làm Sạch

- **Trước khi tiến hành bất cứ việc gì trên máy, kéo phích cắm điện nguồn ra.**
- **Để được an toàn và máy hoạt động đúng chức năng, luôn luôn giữ máy và các khe thông gió được sạch.**

Nếu như cần phải thay dây dẫn điện thì công việc này phải do hãng Bosch, hay một đại lý được Bosch ủy nhiệm thực hiện để tránh gặp sự nguy hiểm do mất an toàn.

### Dịch vụ hỗ trợ khách hàng và tư vấn sử dụng

Bộ phận phục vụ hàng sau khi bán của chúng tôi trả lời các câu hỏi liên quan đến việc bảo dưỡng và sửa chữa các sản phẩm cũng như phụ tùng thay thế của bạn. Sơ đồ mô tả và thông tin về phụ tùng thay thế cũng có thể tra cứu theo dưới đây:

[www.bosch-pt.com](http://www.bosch-pt.com)

Đội ngũ tư vấn sử dụng của Bosch sẽ giúp bạn giải đáp các thắc mắc về sản phẩm và phụ kiện.

[www.powertool-portal.de](http://www.powertool-portal.de), cổng thông tin điện tử cho thợ thủ công và người làm việc vật.

Trong tất cả các phản hồi và đơn đặt phụ tùng, xin vui lòng luôn luôn nhập số hàng hóa 10 chữ số theo nhãn của hàng hóa.

### Việt Nam

CN CÔNG TY TNHH BOSCH VIỆT NAM TẠI TP.HCM

Tầng 14, Ngôi Nhà Đức, 33 Lê Duẩn  
Phường Bến Nghé, Quận 1, Thành Phố Hồ Chí Minh

Tel.: (028) 6258 3690

Fax: (028) 6258 3692 - 6258 3694

Hotline: (028) 6250 8555

Email: [tuvankhachhang-pt@vn.bosch.com](mailto:tuvankhachhang-pt@vn.bosch.com)

[www.bosch-pt.com.vn](http://www.bosch-pt.com.vn)

[www.baohanhbosch-pt.com.vn](http://www.baohanhbosch-pt.com.vn)

### Campuchia

Công ty TNHH Robert Bosch (Campuchia)

Đơn nguyên 8BC, GT Tower, Tầng 08,  
Đường 169, Tiệp Khắc Blvd, Sangkat Veal Vong,  
Khan 7 Makara, Phnom Penh

VAT TIN: 100 169 511

Tel.: +855 23 900 685

Tel.: +855 23 900 660

[www.bosch.com.kh](http://www.bosch.com.kh)

### Sự thải bỏ

Máy, linh kiện và bao bì phải được phân loại để tái chế theo hướng thân thiện với môi trường.



Không được thải bỏ dụng cụ điện vào chung với rác sinh hoạt!

